



Date: 20181221

Docket: T-1556-12

Citation: 2018 FC 1302

Ottawa, Ontario, December 21, 2018

PRESENT: The Honourable Madam Justice Elliott

BETWEEN:

HUMAN CARE CANADA INC.

Plaintiff/Defendant by Counterclaim

and

EVOLUTION TECHNOLOGIES INC.

Defendant/Plaintiff by Counterclaim

PUBLIC JUDGMENT AND REASONS

TABLE OF CONTENTS

I.	Overview	4
A.	Nature of the Action	4
B.	The Parties and Their Products	5
	(1) Human Care	5
	(2) Evolution	6
C.	The Mobility Aiding Device Market in Canada	7
D.	The 392 Patent	9
II.	Facts Agreed Upon	11
III.	Preliminary Issues	14
A.	Commercial Embodiment and Commercial Success	15
	(1) Mr. Macmillan's Examination-in-Chief	15

(2)	Dr. Brienza’s Expert Report	16
(3)	Rulings on the Objections	17
B.	Evolution’s Inventory Cost (“COGS”) Increases	18
C.	Nonsuit	21
D.	Lane Patent	25
IV.	Witnesses	28
A.	Human Care’s Fact Witnesses	29
(1)	Douglas Macmillan	29
(2)	Jeffrey Fishbein	31
(3)	Rick Synkowicz	33
B.	Evolution’s Fact Witnesses	34
(1)	José-Luis Pita	34
(2)	Stephen Liu	36
C.	Human Care’s Expert Witnesses	37
(1)	Dr. David Brienza	37
(a)	Evolution’s Critique of Dr. Brienza	39
(b)	Evolution’s Challenge to Dr. Brienza’s Credentials	40
(2)	Nancy Rogers	42
(a)	Evolution’s Critique of Ms. Rogers	43
D.	Evolution’s Expert Witnesses	43
(1)	Jonathon Schuch	43
(a)	Human Care’s Critique of Mr. Schuch	44
(2)	Mark A. Gain	45
(a)	Human Care’s Critique of Mr. Gain	46
V.	Issues	46
VI.	The Claims in Issue	47
VII.	Claims Construction	49
A.	The Law	49
B.	The Approach to Claims Construction by Dr. Brienza and Mr. Schuch	54
C.	The Person of Ordinary Skill in the Art [POSITA]	56
D.	Common General Knowledge [CGK]	59
E.	The Essential Elements of the Claims in the 392 Patent	62
(1)	Essential Elements Agreed Upon	64
(2)	Essential Elements Disagreed Upon	64
(3)	The Approach to a Purposive Construction of the Essential Terms in Dispute	64
(4)	Tension Rod Means	66
(5)	Tension Rod Structurally Interconnects	71
(6)	First and Second Supports	77
(7)	Handle	81
(8)	First and Second Cross Braces	88
VIII.	Infringement	93
A.	The Law	93
B.	General Comments on the Infringement Issues between the Parties	94
(1)	The Preferred Embodiment	95
C.	The Xpresso Rollator Infringes the 392 Patent	97
(1)	Tension Rod Means and Tension Rod Means Structurally Interconnects	99

(2)	First and Second Supports	99
(3)	Handle	100
(4)	The First and Second Braces	101
IX.	Validity	102
A.	Rulings on the Objections Relevant to the Validity	103
B.	Anticipation	106
(1)	The Law	106
(2)	The 392 Patent was not anticipated	109
C.	Obviousness	109
(1)	The Law	109
(2)	The Inventive Concept	114
(3)	Essence of the Invention	115
(4)	The 392 Patent was not obvious	116
(a)	Commercial Success	117
D.	Overbreadth	118
(1)	The Law	118
(2)	The Arguments of the Parties	121
E.	Mere Aggregation	122
(1)	The Law	122
(2)	The 392 Patent is not a mere aggregation	123
X.	Remedies	124
A.	Damages – Reasonable Remedy	124
B.	Is Human Care Entitled to Evolution’s Profits in Respect of Its Xpresso Products?	125
C.	Agreed Upon Facts Relevant to an Accounting of Profits	126
D.	General Legal Principles of an Accounting of Profits	127
E.	Evolution’s Differential Profits Approach	128
F.	Analysis of Evolution’s Differential Profits Approach	130
G.	The Appropriate Accounting Method to Determining Evolution’s Profits	132
H.	What Costs, if any, are Deductible from Evolution’s Xpresso Revenues, and in What Proportion?	133
(1)	Deductible Expenses Claimed by Evolution	135
(a)	Sales and Administrative Costs – EVO-56	135
(b)	Accounting and Legal Fees	136
(c)	Consulting Fees	137
(d)	Other Discretionary Deductions Claimed	138
I.	Conclusions on Accounting of Profits	138
J.	Is Human Care Entitled to a Permanent Injunction?	139
K.	Should Profits-on-Profits be granted	139
XI.	Costs	139
XII.	Pre- and Post-Judgment Interest	140

I. **Overview**

A. *Nature of the Action*

[1] The Plaintiff, Human Care Canada Inc. [Human Care] and the Defendant, Evolution Technologies Inc. [Evolution] each manufacture products called rollators in the industry of mobility aiding devices. While members of the public commonly call rollators “walkers”, they are in fact a separate product— a rollator is a “walker” with wheels.

[2] Human Care claims that Evolution has infringed Claims 16 and 18 of Canadian Patent No. 2,492,392 [the 392 Patent] of which it is and has been a patentee or, a person claiming under a patentee, throughout the relevant period. Human Care alleges that Evolution’s Xpresso rollator [Xpresso] features all the essential elements of those two claims.

[3] Human Care seeks:

- A. a declaration that Evolution's Xpresso products have infringed claims 16 and 18 of Human Care's 392 Patent;
- B. dismissal of Evolution's counterclaim in its entirety on the basis that the 392 Patent is valid; and
- C. remedies be granted, including:
 - i. a permanent injunction issued restraining Evolution from infringing the 392 Patent;
 - ii. reasonable compensation be awarded for infringement during the period when the application became open to the public and when the patent was issued, including Evolution’s profits made as a result of selling the infringing products;
 - iii. a direction that Evolution immediately deliver to Human Care all articles in its possession, power or control that fall within the ambit of the 392 Patent; and

- iv. pre-judgment and post-judgment interest and costs of this action as determined by this Court.

[4] Evolution defends the infringement action on the basis that the Xpresso lacks five essential elements found in Claims 16 and 18 of the 392 Patent.

[5] Evolution also counterclaims that the 392 Patent is invalid because it was anticipated by another patent, was obvious given the prior art, is not inventive but was a mere aggregation of known parts and, the claims in the 392 Patent are broader than the invention actually made or described. In support of the counterclaim, a list of 54 pieces of prior art is attached as a schedule to the Second Amended Statement of Defence and Counterclaim.

[6] In the Second Amended Reply and Defence to Counterclaim, Human Care denies Evolution's allegations and asserts that the commercial success of the invention demonstrates that the 392 Patent is inventive and not obvious.

[7] For the reasons that follow, I have concluded that the 392 Patent is valid and that it has been infringed.

B. *The Parties and Their Products*

(1) Human Care

[8] Human Care is an Ontario corporation located in Nepean, Ontario. It is a subsidiary of a global manufacturer and supplier of home healthcare products, including walkers and other mobility aiding devices.

[9] In 2007, Human Care of Sweden acquired the Canadian company Dana Douglas Inc. As a result, the Plaintiff, Human Care, is the Canadian subsidiary of a Swedish mobility products company that also has offices in Austin, Texas, the Netherlands, and Melbourne, Australia. Globally Human Care has about 100 employees.

[10] Douglas Macmillan and his father, Dana Macmillan, started Dana Douglas. It first began selling rollators in Canada in 1990 by importing them from Holland. Later, it struck a deal whereby it would sell in North America the products of a manufacturing facility in Taiwan, which would sell them everywhere else. When the manufacturer opened a distribution centre in the United States, Dana Douglas decided it needed to control its own destiny and develop its own products. The first such product was called the Infiniti.

[11] Of interest in this matter is a rollator which Human Care markets under the brand name "Nexus." Mr. Macmillan indicated that when it was launched in late 2004 the Nexus was the only cross-folding (side to side) rollator in the world with a centre-folding solid seat. All other rollators folded front to back or, if they cross-folded, they had a sling-type seat.

(2) Evolution

[12] Evolution is a privately owned corporation that was incorporated in British Columbia. It has a global business which supplies mobility aiding devices for consumers.

[13] The sole shareholder, President and CEO of Evolution is Julian Liu. He is the person in charge of all aspects of the business of the company. Mr. Liu oversees Evolution's profitability

and quality control; he negotiates contracts such as those with the factory and with the exporting company. Mr. Liu's wife, Alice Chen, and son, Stephen Liu, are also involved with the operations of Evolution.

[14] The Evolution rollator, which allegedly infringes the 392 Patent, is marketed under the brand name "Xpresso." It is agreed that all Xpresso rollators have a centre-folding frame. The term "centre-folding" is agreed to refer to a walker and/or rollator that folds laterally (or side folds), the folding of which is initiated by the user pulling on a handle.

[15] It is also agreed that Evolution does not have a license in respect of the 392 Patent.

[16] In addition to Evolution, Mr. Liu owns a company located in China that sells point-of-sale software units to beauty salons in China. That product is also called Xpresso.

C. *The Mobility Aiding Device Market in Canada*

[17] Mobility aiding devices are typically used by persons for assistance with their daily activities by providing support during activity or movement. These devices include canes, crutches, walkers, wheelchairs and rollators.

[18] Historically, mobility aiding devices have been used for centuries. Wheeled chairs to carry people are said to have been in use as early as the 6th Century. The first patent for a wheelchair with a full reclining back was issued in 1869. More recently, in the 1930s, a folding wheelchair with a sling seat was invented and is still in use today. Wheelchairs have continued to

evolve over time. As is well known, today there are various specialized wheelchairs including electric wheelchairs, wheelchairs designed for specific sports, and wheelchairs that can be manoeuvred by quadriplegics.

[19] Walkers originally consisted of a non-folding frame with handgrips and four or more legs. These walkers required the user to lift and position the walker between taking steps. In the 1970s, light weight folding walkers with wheels entered the market. The user could push or roll the walker without lifting it to take steps.

[20] The first rollator was a four-wheeled rolling walker invented in 1978 by a Swedish woman for her personal use. In contrast to a walker, a rollator usually includes brakes, handles, and a seat as well as a frame and wheels.

[21] It is expected that rollators will be used outside. As such, they need to be stable in use and flexible enough to be put in the trunk of a car for transporting. Users often sit on their rollators so they also need to be able to support the user's weight without collapsing.

[22] In Canada mobility aiding devices are sold to the public directly via websites and through home medical equipment dealers. There are hundreds of independent dealers in addition to large corporate dealers such as Motion Specialties, Shoppers Home Healthcare, and Home Medical Equipment. The dealers carry products from a variety of manufacturers or distributors whose sales persons actively seek out their business. Physical therapists may also make specific product recommendations to clients.

D. *The 392 Patent*

[23] The 392 Patent was filed on January 14, 2005 claiming priority as of March 26, 2004 by United States Patent 10/809,334. The 392 Patent will expire on January 14, 2025. It was opened to the public on September 26, 2005 and was issued on November 30, 2010.

[24] The named inventors of the 392 Patent are Mr. Ross Lyell Cowie and Mr. Bjarki Hallgrimsson. The owner of the 392 Patent is the Plaintiff, Human Care.

[25] The 392 Patent is entitled “Mobility Aiding Device.” The “Technical Field” of the invention sets out that “[t]he present invention relates to a mobility aiding device, and in particular to a wheelchair, a walker, a transport chair, a shower seat or a rollator with a solid seat, which is hinged in the middle to enable the device to be easily folded into a storage position.”

[26] The “Background of the Invention” [Background] indicates that a large, aging, urban population has created an increased demand for various mobility aiding devices. It states that existing mobility aiding devices such as walkers and rollators have become more popular than wheelchairs, crutches or canes because of their added structural support and versatility. A highly sought after feature is the ability to fold up into a storage position for travel or simply to save space when not in use. While conventional wheelchairs have had the ability to fold two sides of the frame into a storage position, they have always had a flexible or hammock seat. It is said that a hard platform is now desired to provide comfortable seating and usable supporting structure for other items.

[27] The Background then identifies various faults found in the prior art:

- complicated one-piece seats require a great deal of manual dexterity and strength to open and close a device;
- two-piece seats require extra support panels which are accessed from below the seat; and
- two-piece seats employ extra-wide abutting surfaces between the pivoting seat panels and those abutting seats (a) can pinch body parts and (b) are not always strong enough for long-term use.

[28] The Background section concludes by identifying the problem to be solved by the 392 Patent as “to overcome the shortcomings of the prior art by providing a mobility aid . . . with a solid seating platform made up of[f] two pivotally connected sections, with structural reinforcements that fold up easily into a storage position.”

[29] The “Summary of the Invention” describes in general terms two variations of the mobility aiding device adjustable between a use and a storage position.

[30] There are nine drawings in the 392 Patent depicting preferred embodiments. The drawings show the preferred embodiments from differing viewpoints. There are four different views of the rollator: isometric views of it in a use position and in a storage position; a front view and a side view. There are five different views of the chassis: an isometric view, a front view, an end view looking up from below the seating platform, an end view in a partially collapsed position, and an end view in the storage position.

[31] The “Detailed Description” of the drawings found at paragraphs 30 to 39, refers to the nine figures which depict various elements of the embodiment shown. The paragraphs mirror the

claim language and provide additional information such as that the chassis “is preferably made up of a lightweight high-strength material, such as aluminum” and “if the present invention were to be used with a walker or shower seat, the front and rear wheels could be replaced by end caps made of [f] rubber or some other non-slip material.”

[32] There are eighteen claims in the 392 Patent. Claims 16 and 18, which Human Care says have been infringed by Evolution, are independent claims as are Claims 10, 12, 14, 15 and 17. Evolution has challenged the validity of all eighteen claims.

II. **Facts Agreed Upon**

[33] The first exhibit entered at trial was an Agreed Statement of Facts [ASF] tendered on the basis that the contents of the agreement did not constitute an admission by either party of the relevance of the facts agreed upon or the weight, if any, to be given to them at trial.

[34] In the ASF, certain non-contentious terms were agreed upon. For example, there is an agreement as to the meaning of a centre-folding rollator:

“Centre-folding” refers to a walker and/or rollator that folds laterally (or side folds), the folding of which is initiated by the user pulling on a handle;

[35] The relevant dates for the 392 Patent and extracts from parts of the 392 Patent were also set out and agreed upon as were the names of the inventors and that Human Care is the current owner of the 392 Patent.

[36] The ASF contains a short summary of the development of the 392 Patent. It refers to an email from Mr. Macmillan to one of the inventors, Mr. Hallgrimsson, which included reference to two United States Patents known in these proceedings as “Fernie” and “Loodberg” and which was forwarded by him to the other inventor Mr. Cowie.

[37] The total annual external sales revenues, total annual Nexus rollator sales revenue and the revenue that Human Care earned on its Nexus rollators as a percentage of its external sales revenue during the period 2006 to 2015 are agreed to and set out in a table format in the ASF. This agreement obviated the need for either of the parties to prove any documents underlying the numbers in the table including the financial documents relied on by either of their accounting experts.

[38] There is an acknowledgement that Evolution first sold the Xpresso rollators in July, 2008 and that they have a centre-folding frame. There is also confirmation that Evolution has offered for sale, sold, imported into Canada and exported from Canada a number of named Xpresso rollators in various sizes and that the Xpresso Zero has been assembled in Canada since July 2008. Xpresso Parts & Accessories are defined in the ASF and are said to have been offered for sale, sold, imported into Canada, exported from Canada and assembled in Canada by Evolution from July 2008 to present.

[39] It is agreed that Evolution does not have a license in respect of the 392 Patent.

[40] There is an agreement that there is no prior anticipatory disclosure of the invention under paragraph 28.2(1)(a) of the *Patent Act*, RSC 1985, c P-4 [*Patent Act*].

[41] If the 392 Patent is found to be valid and infringed under ss. 55(2) of the *Patent Act*, an amount is agreed upon for a reasonable royalty to be paid for Evolution's use of Human Care's patented technology from the date of launch of the Xpresso in July 2008 until the 392 Patent was issued on November 30, 2010. The royalty rates for, and the total number of Xpresso rollators sold, between July 1, 2008 and November 30, 2010 is agreed upon. The royalty rate is based on the actual royalty rates paid in respect of the Nexus rollators from 2006 to 2011 calculated from July 1, 2008 up to July 1, 2010 and from July 1, 2010 to November 30, 2010.

[42] To assist with the calculation of an accounting for profits, a table sets out the Xpresso rollator unit sales from December 1, 2010 to June 30, 2016. There is a stipulation as to the total sales revenue from Xpresso Products, as defined earlier in the ASF, for the same time period. There is also agreement between the parties as to the Xpresso Product Freight Costs for that same time period.

[43] Facts that have been agreed upon, in addition to the foregoing, are interspersed throughout this Judgment and Reasons.

III. **Preliminary Issues**

[44] During the course of the trial, there were a number of objections. Some objections were ruled on immediately; others were reserved and will be addressed as necessary during the course of this Judgment and Reasons when the subject matter of the objection is being reviewed.

[45] There was also a motion for nonsuit at the close of the Plaintiff's case. The nonsuit motion is dismissed for the reasons set out below.

[46] Human Care raised an objection about Evolution's reliance on an American patent as its inspiration for the Xpresso. That objection is sustained and the reasons are provided in this decision.

[47] Human Care also objected to Evolution's increased inventory costs. This objection is analyzed in this decision and is sustained.

[48] After receipt of the written closing submissions, correspondence was received from each party concerning Evolution's submissions with respect to invalidity based on anticipation. That objection is dealt with as part of the discussion of whether the claims in the 392 Patent were anticipated.

[49] Two matters which were briefly taken under reserve and determined on day two of the trial are outlined and determined below.

A. *Commercial Embodiment and Commercial Success*

[50] During the examination-in-chief of Mr. Macmillan on the first day of trial, counsel for Evolution objected under Rule 248 of the *Federal Courts Rules*, SOR/98-106 [*Rules*] to Human Care presenting any facts or information or making any submissions with respect to the Nexus rollator being the commercial embodiment of the 392 Patent. The same objection was then made with respect to any sales of the Nexus rollator or evidence that it was a commercial success. The basis for the objections was that Human Care had refused to answer a number of questions on discovery related to both commercial embodiment and commercial success.

[51] In addition, Evolution objected to any submissions being made regarding the Nexus and, in particular, any facts or evidence by any witness that the Nexus is a commercial embodiment of the 392 Patent. This objection encompassed Dr. David Brienza's Expert Report and his statements as to the Nexus being the commercial embodiment of the claims in the 392 Patent and any fact evidence being put forward by any witness as to the commercial success of the Nexus.

[52] At the opening of the second day of trial, I provided oral rulings denying the objections. A brief summary of the objections and rulings follows.

(1) Mr. Macmillan's Examination-in-Chief

[53] The objection addressing whether evidence of the commercial success of the Nexus could be led was an issue closely connected to the commercial embodiment argument. It arose when counsel for Evolution objected to Mr. Macmillan mentioning the "tremendous success of the cross-fold", in response to counsel for Evolution asking "what cross-fold," Mr. Macmillan,

presumably being unaware of the commercial success argument, immediately answered “the Nexus.” We were then away to the races.

[54] Counsel for Evolution was well prepared, reading a number of examples of questions posed during discovery of Mr. Macmillan regarding the Nexus and the answers by his counsel which tended to be either the question was not relevant or, it was a matter of expert opinion.

[55] Human Care submitted in response to this objection that answers had been given and there was a pleading amendment claiming commercial success of the Nexus.

(2) Dr. Brienza’s Expert Report

[56] Evolution objected under Rule 52.2 to Dr. Brienza’s Expert Report on the basis that there was no analysis, just conclusions based on his review of photos of the Nexus. As such Evolution sought to exclude the report under Rules 279 and 280 because it had not been prepared in accordance with the Court’s expert code of conduct. Rule 52.2 requires that facts and assumptions be provided in the report to support the reasons for each opinion given.

[57] Human Care replied that the expert report and will-say statements had been in the hands of Evolution since before the pretrial conference but had not been objected to by Evolution. In addition, Evolution had been on notice that Human Care took the position that the Nexus is the commercial embodiment of the 392 Patent since after the first round of discovery and the pleading amendment clearly state that commercial success was being claimed.

(3) Rulings on the Objections

[58] After hearing the arguments, reviewing the documents provided or referred to and considering the case law, I found the objections were not well founded for a variety of factors which were outlined in my oral reasons. In addition, I held that the concerns as to the question of commercial success or otherwise of the Nexus and the contents of Dr. Brienza's reports were best challenged by cross-examination.

[59] At trial I added and, reiterate here, that in any event I would have exercised my discretion to waive compliance with the *Rules* given the length of time that answers had been provided to questions posed in discovery and considering that each side failed to take active steps to address the matters raised in the objections at either the case management conference or the pretrial conference.

[60] On the Rule 248 objection, I found that despite the submission that no answers were provided during discovery answers were in fact given.

[61] I specifically addressed that Rule 248 only applies if a proper question has been asked and there has been a refusal to answer the question either at that time or subsequently. The questions which were put to Mr. Macmillan in April of 2015 were objected to on the basis that he was not properly qualified to answer them as they were a matter of expert opinion. Therefore, they were not proper questions. Additionally, the commercial embodiment questions were subsequently answered on July 8, 2015 stating that the Nexus 1, 2 and 3 rollators were commercial embodiments of the 392 Patent. The pleading amendment made by Human Care in

the counterclaim referred to the Nexus rollator as being the embodiment of the invention in the 392 Patent.

[62] On the Rule 52.5 objection, I found that the conclusion in the Expert Report could not be divorced from the balance of the report in which Dr. Brienza had reviewed Claims 1 to 15 and his infringement report was referred to in his Responding Report where he detailed the provisions of Claims 16 and 18 of the 392 Patent.

[63] In addition, Dr. Brienza referred extensively to the drawings and he examined the claims in the 392 Patent. It simply could not be said that the conclusions he drew were not supported by facts, assumptions and analysis.

B. *Evolution's Inventory Cost ("COGS") Increases*

[64] During the hearing, Human Care brought an objection with respect to Evolution's inventory cost ("COGS") increase. That is, Human Care objects to Evolution's alleged reliance on increased COGS under Rule 248 of the *Rules*. Human Care claims that because Evolution was not questioned about the increased cost at discovery such information should not form the basis of my determination.

[65] In particular, Human Care asserts the following:

- After two rounds of examinations for discovery, Mr. Pita claimed that—based on EVO-49—the inventory costs for Xpresso Lite and Xpresso Original and Tall was ■■■ and ■■■ respectively.

- On August 8, 2016, Evolution allegedly provided new invoices for Fine Faith that demonstrate that the cost of Xpresso rollators range from [REDACTED] to [REDACTED].
- In light of the new unit price, Human Care demanded that Evolution answer four pages of written interrogatories before the trial. Evolution refused. Therefore, Human Care claims that it did not have sufficient discovery of the Xpresso's unit price and was prejudiced in the process.

[66] Evolution argues that Human Care is misinterpreting Mr. Pita's statement and, is seeking another round of discoveries. Specifically, Evolution's position can be summarized as follows:

- Mr. Pita was not opining generally about the cost of Xpresso rollators; rather he was describing one particular invoice that Ms. Wall was asking about.
- Evolution provided all relevant documents (EVO-57 to EVO-63) three months before the second round of discovery.
- It is evident in these invoices that the unit cost of the Xpresso varies.
- Evolution did not answer the written questions before trial because (i) the questions were a veiled attempt at another round of discovery; and (ii) the *Rules* only allow for both oral and written discovery if the parties consent (or with leave from the Court). Neither applied here.

[67] I find that Evolution did not provide Human Care adequate opportunities to raise questions about COGS for three reasons.

[68] First, Evolution's argument that Human Care had access to the relevant invoices during the two rounds of discovery is inaccurate. Human Care was only provided with invoices for Fine Faith for 2008-12 (EVO-49) during the discoveries. These invoices indicated that the unit cost of the rollators were [REDACTED] and [REDACTED]. It was only after the two rounds of discovery that Evolution provided more comprehensive invoices that showed a higher cost per unit.

[69] Second, Evolution says that the materials given after the two examinations for discovery were means to verify the invoices that were disclosed earlier. In effect, they are not "new". However, EVO 57 to 63—the invoices disclosed before the two rounds of discovery—contain piecemeal information about Fine Faith and would not allow anyone to get a firm picture of the impugned unit price.

[70] Third, Human Care made reasonable efforts to obtain information about the unit price, especially in relation to Fine Faith. Some examples include:

- When Mr. Pita was examined in 2015, he confirmed that the unit price was [REDACTED] and [REDACTED] respectively. In the exchange, it is easy to see that perhaps Human Care's counsel, Ms. Wall, was speaking about the price at large and Mr. Pita was just interpreting one invoice (which Evolution claims is the case). Nevertheless, Ms. Wall is assured that this price pertains to "all" rollators. Evolution undertook to advise otherwise if Mr. Pita was wrong.

- Human Care’s counsel is assured again that the price is [REDACTED] and [REDACTED] during discoveries in December 2015.

[71] It is incorrect to say that Human Care failed to ask about the unit cost. It did so repeatedly in its questioning of Evolution’s witnesses. Rather, Evolution has been unable and/or unwilling to provide such information.

[72] In view of the above three findings, I conclude that Rule 248 prohibits Evolution from relying on information about increased COGS. This Court has recognized that Rule 248 “aims to avoid a party being prejudiced by late disclosure of documents or information and to prohibit ‘trial by ambush’”: *Airbus Helicopters, SAS v Bell Helicopter Textron Canada Limitée*, 2017 FC 170 at para 18; *Apotex Inc v Sanofi Aventis*, 2010 FC 481 at para 6. Evolution’s failure to provide timely and complete information has done precisely what the case law warns against— it has prejudiced Human Care’s ability to properly question Evolution’s witnesses. Therefore, I will not consider Evolution’s COGS increases in my assessment.

C. *Nonsuit*

[73] At the close of Human Care’s case on infringement, Evolution moved for nonsuit on the grounds that Human Care had not met its burden to prove on a balance of probabilities that the Xpresso rollator fell within the scope of the claims of the 392 Patent.

[74] The basis for the allegation was a comparison of the testimony of Dr. Brienza at trial and in his Expert Report through which Evolution concluded that under Dr. Brienza’s interpretation

of the 392 Patent the Xpresso rollator did not fall within Claim 16 or 18 because it lacked an essential element: a pivotally connected support to the frame member.

[75] This in turn was based on Dr. Brienza describing the connection of the first and second supports to the first and second frame members in the 392 Patent as being described by a direct connection. This was contrasted with paragraph 40 of Dr. Brienza's Expert Report where he said the cross braces were connected to the supports and the frame members either directly or indirectly via one or more components such as a hinge or bracket. The conclusion drawn by Evolution was that there was an indirect connection between the supports and the frame members of the Xpresso and, therefore, the Xpresso did not fall within the 392 Patent which required a direct connection.

[76] Human Care responded to the motion whereupon Evolution was put to its election of whether it wished to call evidence which it did.

[77] I pause here to note that the *Rules* do not provide a process for a nonsuit motion. In *Canadian Union of Postal Workers c Canada Post Corporation*, 2011 FC 25 Madam Justice Bédard in considering a nonsuit motion reviewed the fact that the Rules of this Court in 1978 addressed the effect of a judgment of nonsuit but the specific rule, Rule 339, was repealed when the 1998 *Rules* were adopted. Justice Bédard determined, for reasons set out at paragraph 13 of her decision, that the repeal of Rule 339 did not eliminate the pre-existing right to bring a motion for nonsuit.

[78] The Ontario Court of Appeal has noted that although neither the *Courts of Justice Act*, RSO 1990, c C 43 nor the *Rules of Civil Procedure*, RRO 1990, Reg 194 specifically provide for bringing nonsuit motions, the judges have continued to hear such motions: *FL Receivables Trust 2002-A v Cobrand Foods Ltd*, 2007 ONCA 425 at para 12 [*FL Receivables*].

[79] It may well be that nonsuit is available at common law but, it is not necessary to resolve that question as I have determined that if it is available, whether under the *Rules* or at common law, Evolution has failed to show that there is no case to answer as set out *FL Receivables* at paragraph 14.

[80] In *FL Receivables*, Mr. Justice Laskin canvassed the procedure for a nonsuit motion at paragraphs 13, 14 and 35, and commented on the utility of such motion:

[13] Still, I question whether in this province a non-suit motion in a civil non-jury trial has much value. In Ontario, when a defendant moves for a non-suit, the defendant must elect whether to call evidence. See *Ontario v. Ontario Public Service Employees Union (OPSEU)*, [1990] O.J. No. 635, 37 O.A.C. 218 (Div. Ct.), at para. 40. If the defendant elects to call evidence, the judge reserves on the motion until the end of the case. If the defendant elects to call no evidence -- as Robert Laba elected in this case -- then the judge rules on the motion immediately after it has been made.

[14] A non-suit motion adds to the time and expense of a trial. And because of the election requirement, it has little practical value. Perhaps a defendant bringing the motion sees a tactical advantage in being able to argue first. To succeed on the motion, however, the defendant must show that the plaintiff has put forward no case to answer, in most lawsuits an onerous task. Why not simply take on the less onerous task of showing that the plaintiff's claim should fail? It is small wonder that most commentators consider that in civil judge alone trials, non-suit motions gain little and are becoming obsolete. See Phipson on Evidence, 16th ed. (London: Sweet & Maxwell, 2005) at 274, and John Sopinka, Donald B. Houston & Melanie Sopinka, *The Trial*

of an Action, 2nd ed. (Toronto: Butterworths Canada, 1999) at 151-52.

[. . .]

[35] On a non-suit motion, the trial judge undertakes a limited inquiry. Two relevant principles that guide this inquiry are these. First, if a plaintiff puts forward some evidence on all elements of its claim, the judge must dismiss the motion. Second, in assessing whether a plaintiff has made out a prima facie case, the judge must assume the evidence to be true and must assign "the most favourable meaning" to evidence capable of giving rise to competing inferences. [. . .]

[my emphasis]

[81] Certainly, Human Care put forward more than just "some" evidence on all elements of its claims to show that Evolution had infringed the 392 Patent. On that basis alone, the motion is dismissed.

[82] I would add that the problem with Evolution's analysis was that the testimony at trial of Dr. Brienza referred to a different element—the connection with the supports—than the reference in his Expert Report—cross braces. Dr. Brienza clearly stated during cross-examination as to the type of connection between the Xpresso support and frame member that "the Xpresso is directly connected, pivotally—directly pivotally connected to the frame member so it does fall within the construction." The nonsuit motion can be dismissed on this evidence which I am to assume is true. Attributing the most favourable meaning to that evidence, the Xpresso support is directly connected to the frame member and Evolution has not met its burden of proof.

[83] In the result, the nonsuit motion is dismissed for these reasons.

D. *Lane Patent*

[84] Human Care objected under Rule 248 to Evolution putting forward evidence through its fact witness Mr. Pita to the effect that the inspiration for the Xpresso rollator came from a 1957 United States Patent 2,810,429 [the Lane Patent]. Human Care says this story of inspiration behind the Xpresso rollator was raised for the first time at this trial despite a long history of litigation including previous discoveries of Mr. Pita regarding the development of the Xpresso rollator.

[85] Human Care first became aware of the Lane Patent when it received Mr. Jonathon Schuch's Expert Statement dated September 2016 and it was cited as prior art. However, until the opening of trial, Human Care was not aware of the claim that either Mr. Pita or Mr. Liu took the position that the Lane Patent was the inspiration for the Xpresso as described by Mr. Pita in response to a question from counsel for Evolution:

Q. And the folding structure of the Xpresso down here, these cross braces, these come from –

A. Yeah. We tried different things. We tried even, like, the same as a wheelchair. The wheelchairs would cross like that and tubing, and it wasn't strong enough until we came up -- we saw that this, the design of a wheelchair with a patent from 1957. I think it was called Lane, the fellow who design it, and he had a solid seat in the wheelchair, and it folded. It split in the middle, and it folded like...

Trial Transcript, Vol. 4, P. 729, L 8 – 17.

[86] The basis for the objection, once that testimony was given, is that during discovery on May 20, 2015, Human Care asked Evolution to identify any patents that it was aware of during the development of the Xpresso rollator and to identify any facts relevant to the allegations that

the 392 Patent was anticipated and obvious. Evolution did not disclose the Lane Patent in response to those questions.

[87] Evolution argues that it disclosed to Human Care on the first day of discovery that the Xpresso rollator was based on a famous wheelchair as illustrated by the following exchange:

Q. Also on page 2, there's a heading 'Features,' and under that it says cross style, centre folding mechanism for compact storage and transportation. What is meant by that reference to cross style or X style?

A. [By Mr. Pita]... Wheelchairs have an X. For years, they call it, 'This is an X folding,' because they have a frame that is an X like that, so we just borrow that from the wheelchair lingo.

Q. So it's just a reference to the frame under the walker that allows it to fold?

A. Yes. And this is what is an X because the walker opens like this. When you close it, it goes like that. But this is something that is used in every wheelchair. Every wheelchair manufacturer will talk about that.

Q. And that goes back to your earlier reference where wheelchairs have used centre-folding technology for a while.

A. Yes. Many years

Trial Transcript, Vol. 5, P. 873, L. 17-28; P. 874, L. 1-16.

[88] Evolution observes that Human Care posed no follow-up questions to determine whether there was a particular wheelchair design or document that it had considered; nor were there any questions asked that could be properly updated to provide the information. In fact, Evolution says that the answer provided by Mr. Pita was in response to a question about statements on Evolution's website about the X design.

[89] The question upon which Human Care relies to say that Evolution should have disclosed the Lane Patent was a broad, all-encompassing one to the effect of “what other facts does Evolution have that the subject matter of the claims other than Claims 16 and 18 were disclosed to the public before either January 13, 2013 or before March 26, 2004.” In other words, the Lane Patent is relevant to obviousness and anticipation, and therefore, it ought to have been answered.

[90] Human Care points out that reference to the Lane Patent did not form part of Evolution’s Affidavit of Documents as of February 6, 2014 or any of the three subsequent affidavits of documents up to August 12, 2016. It was first listed in the Supplemental Affidavit of Documents dated October 31, 2016. The August 30, 2017 Affidavit of Documents first produced certified copies of all prior art relied on by Evolution, including the Lane Patent.

[91] Human Care summarizes the issue that despite being examined on discovery on multiple occasions, across two separate actions on the Xpresso rollator, Mr. Pita only stated for the first time at this trial that the Lane Patent was the inspiration for the Xpresso rollator and had been widely known to himself and Mr. Liu since at least 2005.

[92] Counsel for Evolution indicated it did not have the Lane Patent until receiving the Schuch Expert Report and it was only then that he realized it was relevant to the issues of anticipation and obviousness.

[93] In considering this objection, made after hearing all the testimony, I find it unnecessary to come to a conclusion on the Lane Patent objection. This is because, having heard the evidence of

Mr. Pita, considering the history of the parties including read-ins from several discoveries and the chronology of the affidavit of documents, I find that Mr. Pita's evidence at this trial has been vague and inconsistent with his discovery testimony on several points. To be fair, it may well be because he was relaying second-hand information provided to him by Mr. Liu.

[94] The inspiration story of the Lane Patent is simply not credible. It suffers from issues of hearsay with respect to the involvement of Mr. Liu. I did not find Mr. Pita's evidence credible regarding his recollection of the Lane Patent or his involvement with it at an inspirational level. His evidence was clear that Mr. Liu, who did not testify in this matter, claims to have found inspiration for the Xpresso rollator in the Lane Patent.

IV. Witnesses

[95] The parties called a total of nine witnesses: five by Human Care and four by Evolution.

[96] In addition, read-ins from the examination for discovery of the inventors Mr. Hallgrimsson and Mr. Cowie were tendered. As part of the read-ins, a series of documents were included for context. There was no agreement as to the truth of the contents of the statements made in those documents.

[97] There were also read-ins from the examination for discovery of Evolution's witness, Mr. Pita, both in this matter and in a previous action between the same parties.

[98] Mr. Liu was cross-examined by teleconference on December 3, 2014. Part of a condensed transcript of that cross-examination was made an exhibit to the examination for discovery of Mr. Pita, held May 20, 2015, which was entered as an exhibit at trial.

A. *Human Care's Fact Witnesses*

(1) Douglas Macmillan

[99] Mr. Macmillan was the first witness called at trial. For approximately 28 years he was the Vice President or President of first Dana Douglas and then Human Care. As of July 2015, Mr. Macmillan was no longer employed by Human Care.

[100] Mr. Macmillan started in the mobility aiding device business in 1988 or 1989 primarily selling wheelchairs. He gave a brief overview of the history of the products sold by Dana Douglas and Human Care.

[101] Mr. Macmillan first identified a new product opportunity in 2001 or 2002, when he was in Montréal visiting his wife's grandmother at her retirement home. He noticed the residents had to leave their rollators at the entranceway to the dining room and they were then separately taken by wheelchair to their tables to sit. He made inquiries and was told this was because the fire marshal required a specific distance between the dining tables and walls. Those residents who used a folding wheelchair could have it at their tables. The rollators took up too much space as they had to lie on the floor and were deemed a fire hazard. From that observation, Mr. Macmillan believed there was an opportunity to develop a product for long-term care facilities and nursing homes.

[102] After thinking about it, Mr. Macmillan had in mind certain features for a new product. He felt it had to fold side to side and have a solid seat that would fold with the frame. He had observed issues with the sling seat used in wheelchairs at that time. He also had observed that his two young children preferred the swings in the park that had a solid seat because the ones with a strap sank in and pinched their hips.

[103] Mr. Macmillan testified that he had no postsecondary education and was not completely sure he had graduated from high school. In terms of developing a product, Mr. Macmillan knew he was not capable of doing so in part because he was dyslexic. Therefore, he turned to the husband of a friend of his wife, Mr. Hallgrimsson, who was a product designer.

[104] Mr. Macmillan's contribution to product development of the invention in the 392 Patent was to go online to see what patents existed and whether there was anything of interest. Because his reading and comprehension was poor, he did not read the patents but he did look at the pictures.

[105] Regarding side folding rollators, Mr. Macmillan was aware of the Tango, which had a sling seat. Human Care, at the time was a separate company located in Sweden, had a side folding rollator with a solid seat but the seat itself did not fold. Rather it had to come out and around to collapse the rollator. According to Mr. Macmillan, the seat was "very, very weird."

[106] Mr. Macmillan also gave evidence with respect to the new product development process of Human Care, the cost of it and the ability to save costs by leveraging prior development work and parts made for the first in-house product, the Infiniti.

[107] On cross-examination, Mr. Macmillan acknowledged that he did not part with the company on good terms; however, he did not have a financial stake in the outcome of this action. He stated that he received instructions from Sweden to commence the action and at the time—based on crude testing—he was of the view that the Xpresso infringed the 392 Patent. Mr. Macmillan confirmed that he did not know Dr. Brienza nor did he direct him to conduct any particular tests.

[108] Mr. Macmillan was a credible witness. He gave his evidence in a thoughtful and straightforward manner. When he could not recall dates he said so. If he was uncertain, he explained why that was and if he was guessing or surmising he indicated that was the case. He was not at all argumentative. He explained his challenges in reading and that he was better with drawings as he was a visual person given his dyslexia and attention deficit disorder related thereto.

(2) Jeffrey Fishbein

[109] Mr. Fishbein has been a self-employed sales and marketing person in the home medical equipment industry since 1994. He represents a variety of manufacturers and primarily deals with mobility aiding devices including wheelchairs, rollators and wheelchair accessory products.

Mr. Fishbein is active in the Ontario mobility aiding device market selling for manufacturers who compete with Human Care.

[110] From March 1, 1997 to July 31, 2015 he sold products for Dana Douglas and then Human Care. At that time he did not sell any other brands. He confirmed that he no longer sells Human Care products nor does he have any ties to them.

[111] Mr. Fishbein described the launching of the Nexus rollator which he believed was in late 2004. To the best of his knowledge it was the first centre-folding rollator with a solid seat on the market. He described the reception of the Nexus in the market as “a game changer, pretty much a homerun.” He said that compared to the launch of the previous Human Care rollator, the Infiniti, the success of the Nexus was much faster and much greater. It began to take significant market share from the market leader.

[112] On cross-examination, Mr. Fishbein confirmed that no Nexus customer ever told him they liked the tension rod and he personally did not know what a tension rod was or recognize it when it was pointed out to him.

[113] Mr. Fishbein presented his evidence in a straightforward manner. There is no reason to doubt it.

(3) Rick Synkowicz

[114] Mr. Synkowicz is the national sales manager for Human Care, a position he has held since 2012. He is responsible for sales and marketing of the Plaintiff's products in Canada. He began his sales career in 1997 with Coca-Cola. He joined the mobility aiding industry in 2009 working for Invacare Canada [Invacare], a competitor to Human Care. He joined Human Care after working for Motion Specialties in Ottawa.

[115] Mr. Synkowicz gave evidence of the annual sales revenue of Human Care and the contribution of the Nexus rollators to that revenue, confirming the numbers in the ASF of the parties.

[116] Mr. Synkowicz indicated that when he was at Invacare there were discussions that the Nexus had taken over the market as the go-to product for therapists and consumers, displacing Invacare's Legacy rollator as the number one selling brand. Invacare believed the reason they were displaced was because the Nexus was cross folding and had a firm but soft seat while the Legacy had a hard seat and did not cross fold. He indicated that to compete with the Nexus cross fold Invacare launched the Jazz rollator that was cross folding. He said it did not do well in the market because it had a nylon sling seat and, as he described it, the folding mechanism was "a little clunky."

[117] On cross-examination, Mr. Synkowicz confirmed that although he had identified the drawing of the rollator on the front of the 392 Patent as the Nexus III he was not an expert on patents or diagrams.

[118] Other than the forgoing, the evidence Mr. Synkowicz presented, which was largely factual, was not challenged.

B. *Evolution's Fact Witnesses*

(1) José-Luis Pita

[119] Mr. Pita is the Director of Sales and Marketing for Evolution when he first began in that role in May or June of 1994. He is in charge of the Evolution rollators that includes the Xpresso rollators.

[120] Mr. Pita said that the origin of the Xpresso was that therapists had been calling to say the existing walkers took up too much space so could Evolution make one like a wheelchair that would fold up and stay in a storage position. The front to back folding walkers had to be laid on the ground except for the Evolution rollators that could fold front to back and stay in a storage position. However, they still took up more space than the wheelchairs.

[121] According to Mr. Pita, the therapists in Ontario did not want any other rollators but centre folding which he said they "adopted." That resulted in Mr. Liu, the President of Evolution, commissioning in 2002 a professor at the University of Design of Polytechnic in Hong Kong to build a prototype based on what Mr. Pita said was needed: a new, unique, very modern rollator with disc brakes in the front.

[122] According to Mr. Pita, some of the resulting designs were really outlandish such as one with a 12-inch wheel that was clear plastic. There were also centre-folding rollators and ones

with cableless braking systems. Ultimately, although the designers would come up with something, it was complicated and difficult to build as well as too expensive and extremely heavy.

[123] In addressing the centre-folding designs, Mr. Pita said he had showed some pictures of the prototype to customers who then wanted him to bring them in. However, it was determined that it was not practical. Mr. Pita said “we had to go back to the drawing board.” Evolution stopped working on that model around 2004 or 2005.

[124] Mr. Pita indicated at that time that Evolution determined they needed to do something: a different, more conventional design was needed. The professor was commissioned again. Mr. Pita said they looked at many different things ranging from mini-rollators to pediatric designs before they finally started to work on what became the Xpresso three years after.

[125] The development process was that Mr. Pita would ask the dealers what they needed, what they would like to see. He gave that information to Mr. Liu who then worked with the professor to see if it was possible to manufacture.

[126] Mr. Pita indicated they wanted to build a centre-folding walker. Evolution was known in the industry as making the weight-bearing walker, the strongest one in the market, capable of having a 300 pound person use it. To accomplish that he said the design of the frame used tubing that was almost 50% larger than most other walkers. They incorporated a Roman arch as that

design is known for strength. They wanted something that also looked good and was good for marketing.

[127] Mr. Pita confirmed that the President, Mr. Liu, spent most of his time in China where he also has a business selling software for beauty salons. He and his wife handle the day-to-day operations for Evolution while Mr. Liu looks at the overall operations or the “total picture.” As President, he is also the one who oversees quality control, negotiates with manufacturers, suppliers and shippers.

[128] Mr. Pita’s evidence was largely factual and unchallenged other than the already mentioned Lane Patent story.

(2) Stephen Liu

[129] The Operations Manager for Evolution is Mr. Stephen Liu. He joined Evolution in 2010 and has been the Operations Manager since 2012. He oversees the day-to-day operations including hiring and firing, the accounting system and payroll. He is paid [REDACTED] annually as are each of his mother and father.

[130] Mr. Stephen Liu testified that he was not involved with research and development [R&D] for Evolution. He has a degree in applied science from the University of British Columbia and he took a general management course.

[131] Mr. Stephen Liu described his oversight of the accounting system and the types of entries that are made to track sales, purchases and inventory. Sales are tracked through the customer orders which are inputted to the accounting system at face value, regardless of the currency involved. Any currency reconciliation is carried out separately, the details of which were unknown to Mr. Stephen Liu. The order information then generates an invoice.

[132] Mr. Stephen Liu stated on cross-examination that in preparing the financial productions for Evolution in this matter, he did so based on instructions from his father.

[133] While he was a straightforward and believable witness, Mr. Stephen Liu's evidence is of limited utility. In large measure, on the critical issues it was hearsay information from his father.

C. *Human Care's Expert Witnesses*

(1) Dr. David Brienza

[134] Dr. Brienza is a Professor at the University of Pittsburgh's Department of Rehabilitation Science and Technology. He received his Bachelor's Degree in Electrical Engineering from the University of Notre Dame in 1986, his Master's Degree in Electrical Engineering from the University of Virginia in 1988, and his PhD in Electrical Engineering from the University of Virginia in 1991.

[135] Dr. Brienza has been working in the rehabilitation and assistive technology field since 1987. He was selected as a Fellow of Rehabilitation and Assistive Technology Association of North America in 2007 and chaired, among others, the special interest group on seating and

mobility. Dr. Brienza serves on several editorial boards, has taught courses on rehabilitative engineering, and founded a small business devoted to the development of wheeled mobility aids and seating products. Finally, Dr. Brienza has authored over 70 papers and has filed (or has pending) eight patent applications, including patents pertaining to wheelchairs and assistive devices.

[136] Dr. Brienza confirmed that he abided by this Court's code governing expert reports. Moreover as part of his engagement, Dr. Brienza was given a redacted copy of the 392 Patent which did not list who were the inventors and owners of the patent. He did not have the pleadings prior to writing his report; nor did he know whether he was assisting the Plaintiff or Defendant. Finally, Dr. Brienza did not know what the allegedly infringing device was when he prepared his report on infringement.

[137] Dr. Brienza was qualified as an expert in the areas of rehabilitation sciences and assistive devices, which includes mobility aids such as wheelchairs and walkers and rehabilitation engineering design. Dr. Brienza's expertise includes investigating, developing and evaluating technology for mobility and tissue integrity management in relation to assistive devices.

[138] Dr. Brienza submitted an expert report on issues directly related to validity and infringement of the 392 Patent on September 23, 2016 [Expert Report]. In his report, Dr. Brienza stated that the Xpresso contains "all of the elements of claims 16 and 18 of the 392 Patent and that the skilled person would have the same understanding."

[139] On May 19, 2017, Dr. Brienza filed a responding expert report [Responding Expert Report], in which he construed Claims 1 to 15 and 17 of the 392 Patent. He also responded to the findings of Mr. Schuch, the expert for Evolution. In particular, while Dr. Brienza agreed with some of the Mr. Schuch's conclusions, he stressed that he did not agree with Mr. Schuch's construction that any particular term ought to be limited to the exact embodiment(s) set out in the 392 Patent.

[140] In support of his two reports, Dr. Brienza testified that the Xpresso rollator infringes upon the 392 Patent and that it is a valid patent. The relevant portions of Dr. Brienza's reports and testimony are set out and considered throughout this Judgment and Reasons as the claims are construed and the issues of infringement and validity are determined.

(a) *Evolution's Critique of Dr. Brienza*

[141] Evolution has urged that Dr. Brienza's claim construction generally be given less weight than Mr. Schuch's. In brief, the crux of Evolution's concerns are: (1) Dr. Brienza failed to assess the common general knowledge before construing Claims 16 and 18; (2) he failed to consider all the claims together; and (3) he did not adequately consider and survey the prior art.

[142] The allegation that Dr. Brienza failed to assess the common general knowledge is not borne out by the evidence. He confirmed in his examination-in-chief and on cross-examination that he had considered it. Mr. Schuch confirmed in his responding report and in his testimony that Dr. Brienza discussed the common general knowledge in his Expert Report.

[143] Dr. Brienza gave direct evidence to the effect that he did consider all the claims before writing his Expert Report, read through the specification and looked at the figures. His evidence was, in response to a challenge on cross-examination as to whether the claims were plain and unambiguous, “I would always default to reading the whole patent in trying to understand it in its entirety.”

[144] A separate and specific argument was made that Dr. Brienza’s claims construction should be given little or no weight because he relied heavily on the “essence of the invention” in his claim construction. That argument is discussed, and rejected, in the section considering the validity of the 392 Patent.

[145] Evolution alleged that Dr. Brienza did not adequately consider and survey the prior art. It asserted that only after Mr. Schuch’s initial report did Dr. Brienza realize that he “had made an incurable error” by not independently reviewing the prior art. This alleged error is fatal, according to Evolution, because Dr. Brienza needed to search the prior art to determine what the person of ordinary skill in the art could have discovered in a “reasonable diligent search.”

(b) *Evolution’s Challenge to Dr. Brienza’s Credentials*

[146] Evolution argued that Dr. Brienza’s work and his teaching primarily pertained to three areas: pressure ulcer prevention, electrical control systems, and tele-rehabilitation. Evolution submitted that this means Dr. Brienza was not well-versed in mechanical engineering, especially in areas such as the design and development of wheelchair technology, support surface technology, and the technical standards development for mobility technology.

[147] Evolution maintained that while Dr. Brienza is an expert in rehabilitative sciences and engineering, he could not provide expert testimony in such areas where they related to mechanical devices and the analysis of weight-bearing mobility aiding devices because he is not a mechanical engineer.

[148] Dr. Brienza acknowledged that the 392 Patent is generally directed to a person with mechanical engineering knowledge. He also explained the various ways that, through the course of his career, he has had to have and apply a very comprehensive understanding of mechanics and the application of mechanics to problems such as pressure ulcers. He also has obtained a number of patents — many of which are mechanical devices such as a machine that is manipulated to form a shape to be used as a die for cushions.

[149] Dr. Brienza testified that through the electrical engineering program he took — which ultimately resulted in his PhD in electrical engineering — he acquired the necessary knowledge concerning statics and dynamics to discuss the issues in the 392 Patent. He teaches courses in rehabilitation engineering design, including teaching the fundamentals of the engineering design process and specific considerations for developing rehabilitation technology centred on the person and their needs.

[150] Dr. Brienza is the Director of the University of Pittsburgh Rehabilitation Engineering Research Centre on Wheeled Mobility where mobility devices are a focus of the Centre. The Centre's activities are roughly equally divided between development and research activities. He is a fellow in the Rehabilitation Engineering & Assistive Technology Association of North

America [RESNA], and has been a member since 1988. RESNA is the only organization in North America specifically focussed on the field of rehabilitation technology.

[151] Ultimately, the parties agreed that Dr. Brienza could testify to the matters in his reports and he was accepted as an expert in the fields outlined earlier but reserving to Evolution the ability to argue the weight to be attributed to any of his opinions or statements which strayed into other areas. I am satisfied that Dr. Brienza is well qualified to opine on the matters in issue given his vast experience in the industry and his credentials.

(2) Nancy Rogers

[152] Ms. Rogers received a Bachelor's Degree in Administration from the University of Western Ontario. She has been certified by the Canadian Institute of Chartered Accountants as a Specialist in Investigative and Forensic Accounting. She is also certified in Financial Forensics.

[153] The parties agree that Ms. Rogers is a Chartered Professional Accountant and a Chartered Business Valuator who is an expert in the areas of damage quantification, forensic accounting and business valuations.

[154] Ms. Rogers produced three expert reports, which were filed at trial:

1. A two-volume report dated September 23, 2016 [the Rogers Report] in which Ms. Rogers quantified the profits earned by Evolution during the period December 1, 2010 to June 30, 2016 by Evolution allegedly infringing the 392 Patent in using and/or selling the Nexus rollator; Ms. Rogers also calculated Human Care's claim for reasonable compensation during the period September 26, 2005 to November 30, 2010 which amount has been agreed to by the parties;

2. A report dated May 18, 2017 in which Ms. Rogers provided a summary of the revenue earned by Human Care from the sale of its Nexus Rollators and the total revenue earned by Human Care during the period September 26, 2005 and November 30, 2010; and
3. An Addendum Report dated August 9, 2017 in which Ms. Rogers updated the calculations in the Rogers Report as result of a subsequent agreement between the parties by using a set unit price for the Xpresso rollators and incorporating two additional calculation scenarios.

[155] Ms. Rogers applied an “actual profits approach” to calculate Evolution’s gross Xpresso product revenues and she attested to these facts at trial. Her evidence will be discussed in greater detail in the remedies section of this Judgment and Reasons.

(a) *Evolution’s Critique of Ms. Rogers*

[156] Evolution contends that Ms. Rogers “was taking on the role of advocate rather than an independent and objective expert, who sought to justify disregarding costs to drive profits to unreasonable levels.” In particular, Evolution maintains that Ms. Rogers failed to satisfy standard practices for investigative forensic engagements when she considered materials beyond her engagement and only performed calculations that she was asked to do as opposed to conducting a broader investigative analysis to develop her own hypothesis.

[157] These allegations will be explored in the remedies section.

D. *Evolution’s Expert Witnesses*

- (1) Jonathon Schuch

[158] Mr. Schuch is the Director of Occupational Health and Wellness at the University of Virginia Health System. He earned a Bachelor of Science degree in Biological Sciences from

North Carolina State University in 1981 and a Master of Engineering degree in Biomedical Engineering from the University of Virginia in 1984.

[159] Mr. Schuch was qualified as an expert in the field of biomedical engineering and mechanical engineering with a concentration in the design of rehabilitation equipment, rehabilitation technologies, mechanical devices and machines, and in the analysis, and design of mobility aiding devices including but not limited to wheelchairs, walkers and rollators. His testimony was received on the basis that Human Care reserved the right to challenge his expertise on weight, based on cross-examination of his background.

[160] Mr. Schuch prepared reports dated September 23, 2016 and December 15, 2016. In them he opined on the validity of the 392 Patent, reviewed the claims, and found that Xpresso did not infringe on the 392 Patent. The design, for Mr. Schuch, is “nothing more than an aggregation of older parts, with no novel or inventive outcome.”

(a) *Human Care’s Critique of Mr. Schuch*

[161] Human Care had concerns about Mr. Schuch’s background qualifications but agreed he could be qualified as an expert subject to cross-examination which would go to weight.

[162] Human Care made the point at trial that Mr. Schuch is not a mechanical engineer. He does not have an undergraduate or graduate degree in engineering that is ABET certified. He wrote an engineering exam many years after he finished school which allows him to be

recognized as a professional engineer in the State of Virginia. There is no categorization recognizing him as a mechanical engineer that is however how he refers to himself.

[163] Human Care argues that Mr. Schuch engaged in a narrow “result-driven construction.” Mr. Schuch allegedly interpreted words in claims in “isolation, assigning them definitions outside of the claims themselves.” Human Care says that Mr. Schuch did not read the patent in a holistic manner, thus acting contrary to settled law on patent interpretation. It is submitted that his evidence accordingly should be given less weight.

(2) Mark A. Gain

[164] Mr. Gain is a Partner and Senior Vice President of Matson, Driscoll & Damico Ltd. He received his Bachelor of Commerce degree from McMaster University in 1978. Mr. Gain has over 35 years of experience in the field of investigative and forensic accounting.

[165] It is agreed that Mr. Gain is a Chartered Professional Accountant and a Chartered Business Valuator who is an expert in the areas of business valuation, economic loss quantification and forensic accounting.

[166] Mr. Gain provided a report dated April 21, 2017 [the Gain Report] wherein he adopted a “differential profits” approach to calculate how much profit Evolution earned during the period from December 1, 2010 to June 30, 2016 as a result of its infringement of the 392 Patent. He also provided comments on the Rogers Report.

[167] The amount which Mr. Gain calculated as a reasonable royalty to be paid to Human Care for Evolution's Xpresso sales during the pre-grant period of the 392 Patent was accepted by the parties and agreed to in the ASF.

(a) *Human Care's Critique of Mr. Gain*

[168] While Human Care had no critique of Mr. Gain's qualifications, it did object that the analysis in his report was incorrect in law and not supported by the evidence. Therefore, it should be given little to no weight.

[169] These allegations will also be reviewed in the discussion on remedies.

V. **Issues**

[170] At the beginning of trial the parties submitted a joint statement of issues:

1. Who is the person of ordinary skill in the art [POSITA] with respect to the 392 Patent?
2. What was the common general knowledge of the POSITA as of September 26, 2005?
3. How would the POSITA have understood the following terms and limitations in the 392 Patent:
 - A. "first" and "second" support;
 - B. "hinge means";
 - C. "tension rod means";
 - D. "handle";
 - E. "first" and "second" "cross brace";
 - F. "structurally interconnects"; and
 - G. "extending between."

4. Whether the Xpresso rollator infringes Claims 16 and/or 18 of the 392 Patent.
5. Whether the subject matter of the 392 Patent was invalid as of March 26, 2004 on any of the grounds of:
 - A. Anticipation, because of United States Patent No. 5,348,336 [Ferne];
 - B. Obviousness because of Ferne and other prior art listed in the Second Amended Statement of Defence;
 - C. Overbreadth in that the claims are broader than the invention made or described in the specification;
 - D. Being a mere aggregation of previously known parts each giving its own result without any new result flowing from the combination.

[171] The list of terms and limitations has adjusted somewhat. The changes are:

1. The dispute as to “hinge means” is now part of the dispute about how to interpret the supports. It will not be considered as a separate element that needs to be construed.
2. The term “structurally interconnects” is considered with respect to the tension rod means and the supports.
3. “Extending between” is considered with the cross braces.
4. Evolution has raised an additional issue, as a result of testimony at trial, regarding the “pivotal connection” between the supports and frame members. It is discussed in the consideration of infringement.

[172] If the 392 Patent is valid and infringed then there are a number of issues related to remedies. These issues are separately set out in the remedies section of this Judgment and Reasons.

VI. The Claims in Issue

[173] Claims 16 and 18 are in issue for infringement. All eighteen claims are in issue for validity.

[174] Claim 16 reads:

A mobility aiding device adjustable between a use and a storage position comprising:

a first frame member having a pair of ground engaging means at a lower end thereof for engaging ground thereunder;

a second frame member having a pair of ground engaging means at a lower end thereof for engaging the ground;

a first support pivotally connected to the first frame member;

a second support pivotally connected to the second frame member and pivotally connected to the first support, the first and second supports for supporting a weight above the ground in the use position;

hinge means pivotally connecting the first support to the second support enabling the first and second supports to pivot towards each other into the storage position;

tension rod means for distributing the weight between the first and second supports, said tension rod means being adjustable between an extended position in which said tension rod structurally interconnects said first and second supports, when the device is in the use position, and a released position enabling the device to be adjusted to the storage position;

a first cross brace extending between the first support and the second frame member for transferring at least a portion of the weight to the second frame member; and

a second cross brace extending between the second support and the first frame member for transferring at least a portion of the weight to the first frame member.

[175] Claim 18 is identical to Claim 16 other than it does not mention the two cross braces (the last two paragraphs of Claim 16) and, it adds a handle as the last paragraph:

a handle extending through said first support for pivoting said tension rod into the release position, and for pivoting said first and second supports into the storage position.

[176] As set out in the joint statement of issues, several terms in the 392 Patent need to be construed by the Court. The “hinge means” dispute has been subsumed within the dispute with respect to the term “first” and “second” supports. As a result, there are now six claim elements to be construed. In addition, Evolution contends that an additional issue of construction arose during trial when Dr. Brienza construed the term “pivotally connected” with reference to the supports and frame members in two different ways. Pivotally connected is not separately construed as it is part of the construction of both “first” and “second” supports and cross braces .

VII. Claims Construction

A. *The Law*

[177] The Supreme Court of Canada has established in several cases the law to be applied to claims construction. In the course of so doing, it has incorporated jurisprudence from the United Kingdom and occasionally from patent texts and scholarly articles.

[178] An issued patent is an enactment within the definition of “regulation” as set out in ss. 2(1) of the *Interpretation Act*, RSC, 1985, c I-21 and it must be given such interpretation “as best ensures the attainment of its objects” according to s. 12. When interpreting a patent the context in which words are used will “provide clues to their interpretation and a safeguard against their misinterpretation”: *Whirlpool Corp v Camco Inc*, 2000 SCC 67 at para 49(e) [*Whirlpool*].

[179] Cognizant of the issues and arguments in this matter, I find that the summary provided by Mr. Justice Locke at paragraphs 71 to 79 in *Pollard Banknote Limited v BABN Technologies Corp*, 2016 FC 883 provides a useful summary of the law to be applied:

[71] Claims construction is antecedent to consideration of both validity and infringement issues: *Whirlpool Corp v Camco Inc*, 2000 SCC 67 at para 43 [*Whirlpool*].

[72] A patent is not addressed to an ordinary member of the public, but to a worker skilled in the art described as:

[A] hypothetical person possessing the ordinary skill and knowledge of the particular art to which the invention relates, and a mind willing to understand a specification that is addressed to him. This hypothetical person has sometimes been equated with the “reasonable man” used as a standard in negligence cases. He is assumed to be a man who is going to try to achieve success and not one who is looking for difficulties or seeking failure.

[*Free World Trust v Électro Santé Inc*, 2000 SCC 66 at para 44, quoting Fox, Harold G, *The Canadian Law and Practice Relating to Letters Patent for Inventions*, 4th ed, Toronto: Carswell, 1969 at 184]

[73] As stated in *Catnic Components Ltd v Hill & Smith Ltd*, [1982] RPC 183 at 242-243, and quoted in *Whirlpool* at para 44:

A patent specification should be given a purposive construction rather than a purely literal one derived from applying to it the kind of meticulous verbal analysis in which lawyers are too often tempted by their training to indulge. The question in each case is: whether persons with practical knowledge and experience of the kind of work in which the invention was intended to be used, would understand that strict compliance with a particular descriptive word or phrase appearing in a claim was intended by the patentee to be an essential requirement of the invention so that *any* variant

would fall outside the monopoly claimed, even though it could have no material effect upon the way the invention worked.

[Emphasis in original.]

[74] The claims language will, on a purposive construction, show that some elements of the claimed invention are essential while others are non-essential: *Free World Trust v Électro Santé*

Inc, 2000 SCC 66 at para 31 [*Free World Trust*]. Claim elements are presumed to be essential, and a party alleging otherwise bears the onus of establishing non-essentiality.

[75] In construing the claims purposively, it is important to bear in mind that the language of the claims is prime: *Free World Trust* at para 40.

[76] As stated in *Consolboard Inc v MacMillan Bloedel (Saskatchewan) Ltd*, [1981] 1 SCR 504 at 520:

We must look to the whole of the disclosure and the claims to ascertain the nature of the invention and methods of its performance, (*Noranda Mines Limited v. Minerals Separation North American Corporation* [[1950] S.C.R. 36]), being neither benevolent nor harsh, but rather seeking a construction which is reasonable and fair to both patentee and public. There is no occasion for being too astute or technical in the matter of objections to either title or specification for, as Duff C.J.C. said, giving the judgment of the Court in *Western Electric Company, Incorporated, and Northern Electric Company v. Baldwin International Radio of Canada* [[1934] S.C.R. 570], at p. 574, “where the language of the specification, upon a *reasonable view* of it, can be so read as to afford the inventor protection for that which he has actually in good faith invented, the court, as a rule, will endeavour to give effect to that construction.” Sir George Jessel spoke to like effect at a much earlier date in *Hinks & Son v. Safety Lighting Company* [(1876), 4 Ch. D. 607]. He said the patent should be approached “with a judicial anxiety to support a really useful invention.”

[77] If there is more than one construction that can be reasonably reached, the Court must favour the construction which upholds the patent: *Letourneau v Clearbrook Iron Works Ltd*, 2005 FC 1229 at paras 37 and 38; *Pfizer Canada Inc v Canada (Minister of Health)*, 2005 FC 1725 at para 52.

[78] There is arguably an inconsistency between the principle that claim construction is antecedent to consideration of validity issues, and the principle that one should favour a construction that upholds the patent (or approach that patent with a judicial anxiety to support a really useful invention). It would seem that one can

favour a construction that upholds the patent only if one has considered what is necessary to uphold the patent. So, it is not entirely clear whether or not one should consider validity issues when construing the claims. In my view, both of the foregoing principles should work hand in hand. Some clarity may come from the guidance that the Court is not to construe a claim without knowing where the disputes between the parties lie; it is essential to see where the shoe pinches so that one can concentrate on the important points: *Shire Biochem Inc v Canada (Minister of Health)*, 2008 FC 538 at para. 22; *Sanofi-Aventis Canada Inc v Apotex Inc*, 2009 FC 676 at para. 82.

[79] The SCC in *Free World Trust* expressly rejected the use of extrinsic documents such as communications between the applicant and the patent examiner during prosecution of the patent application for the purposes of construing the claims. The Court discussed the fact that there exists a concept of file wrapper estoppel in the US which provides that a patentee cannot recapture ground conceded during prosecution of the patent application to avoid prior art. In this way, correspondence with the patent examiner can be relevant in construing claims of US patents. However, the Court in *Free World Trust* instead chose the route of simplicity, stating at para 66:

To allow such extrinsic evidence for the purpose of defining the monopoly would undermine the public notice function of the claims, and increase uncertainty as well as fuelling the already overheated engines of patent litigation. The current emphasis on purposive construction, which keeps the focus on the language of the claims, seems also to be inconsistent with opening the pandora's box of file wrapper estoppel. If significant representations are made to the Patent Office touching the scope of the claims, the Patent Office should insist where necessary on an amendment to the claims to reflect the representation.

[180] In that same vein, evidence of the inventors concerning the proper construction of the claims is also inadmissible as it too is extrinsic evidence: *Merck & Co, Inc v Apotex Inc*, 2006 FCA 323 at paras 51-53.

[181] Purposive construction requires reference to the entire specification to provide the context necessary to a proper understanding of the words used by the inventor: *Canada Inc v Canada (Health)*, 2007 FCA 209 at para 53, leave to appeal denied November 15, 2007, SCC No 32132.

[182] Purposive construction does not allow one to have an eye on the allegedly infringing device in respect of infringement or an eye to the prior art in respect of validity: *Whirlpool*, at para 49(a). Nor is the patent to be construed with reference to the product alleged to have been made pursuant to its teachings: *Janssen-Ortho Inc v Canada (Health)*, 2010 FC 42 at para 105.

[183] Claims construction involves more than simply taking the words of a patent at face value. In *Whirlpool*, the Supreme Court underscored that the context in which words are used is a critical part of understanding it. In *Free World Trust v Électro Santé Inc*, 2000 SCC 66 [*Free World Trust*], the Supreme Court elaborated on how the words of a patent are to be read, adding a constraint:

51 The words chosen by the inventor will be read in the sense the inventor is presumed to have intended, and in a way that is sympathetic to accomplishment of the inventor's purpose expressed or implicit in the text of the claims. However, if the inventor has misspoken or otherwise created an unnecessary or troublesome limitation in the claims, it is a self-inflicted wound. The public is entitled to rely on the words used provided the words used are interpreted fairly and knowledgeably.

[my emphasis]

[184] The relevant date for claims construction is the date of publication of the 392 Patent which is September 26, 2005.

B. *The Approach to Claims Construction by Dr. Brienza and Mr. Schuch*

[185] Although Dr. Brienza and Mr. Schuch approached their claim interpretation tasks differently from each other, I found them both to be sincere and knowledgeable witnesses. Each of them did their best to answer all questions and be responsive without being combative or engaging in advocacy or debate with counsel. For the most part, they either agreed on matters of construction or the differences were not significant. Of course, there is an important caveat — the areas in which they disagree are significant in that their opinions are very much at odds with each other.

[186] Dr. Brienza interpreted the claims more broadly than Mr. Schuch who took a narrow, more literal approach.

[187] Dr. Brienza conducted a purposive analysis, considering the patent as a whole, the interaction of the claim elements and the specification.

[188] Dr. Brienza has taken a view of the claims that allows them to be upheld; he said he found them relatively straightforward to read and understand. He confirmed his construction with reference to the specification which he said he would always do. His claims construction of elements did not conflict with the same element in any of the other claims. He recognized different constructions of different claims are to be preferred over constructions of different claims that are the same. In so doing, he respected the principle of claim differentiation as set out by Madam Justice Gauthier, in *Eli Lilly and Company v Apotex Inc*, 2009 FC 991 at paragraph 90:

Each part of the specification must be effectively construed and, if it is at all possible, each claim must be construed independently of the others and be given an effective and distinct meaning. The court will not be inclined to construe two claims in a specification as identical, for if one claim bears the same meaning as another it does not bear an effective meaning.

[emphasis is in the original.]

[189] Mr. Schuch first defined a number of the terms he found in the claims based on his understanding of the common meaning of each term. He confirmed that he arrived at the definitions “separate and apart from the claim language.” He also said that he then applied his definitions to the claim construction. Counsel for Human Care put it this way: “Mr. Schuch . . . has looked at the claims, picked at random words, define them outside of the claims, and then reinserted them into the claims.” I find that is an accurate statement of the process Mr. Schuch used.

[190] I am not satisfied that Mr. Schuch considered the language of the claims in context. Rather than consider the actual language of the claims, Mr. Schuch often truncated or changed it. For example, when construing the term “tension rod means,” Mr. Schuch defined a tension rod. Unlike Dr. Brienza, Mr. Schuch did not mention what the word “means” or counter Dr. Brienza’s explanation of it. For the terms “structurally interconnects” or “pivotally interconnect” Mr. Schuch considered the word “interconnect” separately. Dr. Brienza considered that the word “structurally” altered the meaning of the word “connect”. One of the terms in dispute is “extending between”; Mr. Schuch only looked at and construed the word “extending.”

[191] When Mr. Schuch's construction of a claim element resulted in invalidating several claims, he did not seek to revisit that construction to determine whether another interpretation was available that would permit the claims to be upheld.

[192] Counsel for Evolution argues that the words Mr. Schuch defined had meanings that would be readily understood by the POSITA. For them, it was Dr. Brienza who stretched or contorted words such as "tension rod," "extend between" and "interconnect."

[193] Certainly there were occasions where Mr. Schuch did refer to the specification when discussing his claims construction. However, he applied his own definitions, so I will keep in mind the comments of Mr. Justice Stratas, in *Cobalt Pharmaceuticals Company v Bayer Inc*, 2015 FCA 116 to the effect that "cherry-picking particular portions of the patent" is a tendentious approach which is best avoided as the patent is to be examined as a whole construing the language of the claims as set out in *Whirlpool*.

C. *The Person of Ordinary Skill in the Art [POSITA]*

[194] In *Whirlpool*, Mr. Justice Binnie stressed that the POSITA is a person with ordinary skill and the common knowledge of such a person. He referred at paragraph 70 to *Consolboard Inc v MacMillan Bloedel (Sask) Ltd*, [1981] 1 SCR 504 at page 523 where Justice Dickson, as he then was, quoted from *Fox Canadian Patent Law and Practice* (4th ed.) at page 204:

The patent claims were necessarily addressed to the wider world of individuals with ordinary skills in the technology of clothes washing machines. As Aldous L.J. observed in *Beloit Technologies Inc. v. Valmet Paper Machinery Inc.*, [1997] R.P.C. 489 (Eng. C.A.), at p. 494:

The notional skilled addressee is the ordinary man who may not have the advantages that some employees of large companies may have. The information in a patent specification is addressed to such a man and must contain sufficient details for him to understand and apply the invention. It will only lack an inventive step if it is obvious to such a man. [Emphasis added.]

Dickson J. placed the same emphasis on “ordinariness” in *Consolboard, supra*, at p. 523:

The persons to whom the specification is addressed are "ordinary workmen," ordinarily skilled in the art to which the invention relates and possessing the ordinary amount of knowledge incidental to that particular trade. The true interpretation of the patent is to be arrived at by a consideration of what a competent workman reading the specification at its date would have understood it to have disclosed and claimed.

[195] In *Free World*, Mr. Justice Binnie further expands on the definition of the POSITA, stating the following at paragraph 44:

The courts have traditionally protected a patentee from the effects of excessive literalism. The patent is not addressed to an ordinary member of the public, but to a worker skilled in the art described by Dr. Fox as

a hypothetical person possessing the ordinary skill and knowledge of the particular art to which the invention relates, and a mind willing to understand a specification that is addressed to him. This hypothetical person has sometimes been equated with the “reasonable man” used as a standard in negligence cases. He is assumed to be a man who is going to try to achieve success and not one who is looking for difficulties or seeking failure.

(Fox, *supra*, at p. 184)

It is the “common knowledge” shared by competent “ordinary workers” that is brought to bear on the interpretation: Fox, *supra*,

at p. 204; Terrell on the Law of Patents (15th ed. 2000), at p. 125;
I. Goldsmith, Patents of Invention (1981), at p. 116.

[196] Dr. Brienza and Mr. Schuch largely agree on the attributes of the POSITA. They disagree only with respect to the amount of work experience a person without an engineering degree would require. At trial, this difference was accepted by Mr. Schuch as not material.

[197] Dr. Brienza's opinion, which was shared by Mr. Schuch, as set out above, that the person of skill in the art could be a person with engineering knowledge, or could be a team. Experience would be a substitute for formal engineering training.

[198] The level of education would drive the level of required rehabilitation product design experience of the skilled person. More such design experience would require less formal education and more education would require less design experience.

[199] An understanding of the needs of the population for whom the product is intended is required. The POSITA would also have knowledge of which materials to use for particular design purposes.

[200] Having considered the testimony and the reports of the experts, I find that the person or team of persons to whom the 392 Patent is addressed would have the following qualifications and experience in order to follow the 392 Patent and put the invention therein into practice:

- some knowledge of mechanical mechanisms and materials experience in designing rehabilitation products such as walkers, rollators and/or wheelchairs; and,

- an understanding of the rehabilitation product design process and the needs of the population for whom the product is intended as well as knowledge of which materials to use for particular design purposes; and,
- some demonstrated experience designing similar rehabilitation product devices then that would substitute for a college degree in engineering; such an individual may be trained at a trade school with one to two years of experience designing similar devices; or,
- an undergraduate degree in engineering would be sufficient with some added rehabilitation product experience, such as experience with engineering design in a design project; or,
- an individual with a master's degree or a PhD would have sufficient knowledge with some lesser level of experience, such as in a design project.

D. *Common General Knowledge [CGK]*

[201] Determining what constitutes the CGK is a factual finding; it does not amount to all information in the public domain. It includes knowledge of patents but not knowledge of all patents. It is the subset of patents, journal articles and technical information which is generally acknowledged by POSITAs as forming part of the CGK in the field to which the patent relates:

Bell Helicopter Textron Canada Limitée v Eurocopter, société par actions simplifiée, 2013 FCA 219 at paras 63-65.

[202] It is agreed by both experts that the CGK would include a basic understanding of human functional capacity with a focus on disabilities or functional limitations affecting ambulation.

[203] It is also agreed by the experts that the CGK would include knowledge of a range of mobility aiding devices, their design process, and the needs and limitations of those for whom they are intended. In that respect, the POSITA would possess some knowledge of static, dynamic and cyclic loading of structures and the effect of those loads on structures and structural

members. This would include a moderate knowledge and understanding of: (1) the design of mechanical components and structures to withstand those loads and to maintain stability; and (2) the selection of materials to achieve the design goals.

[204] Mr. Schuch and Dr. Brienza were both of the view that the CGK would include consideration of mobility aiding devices such as wheelchairs, walkers, strollers and rollators. They differ as to whether any CGK would be found in everyday structures and elements of long standing, but are not necessarily related to, mobility aiding devices.

[205] Mr. Schuch would include within the CGK items such as trauma stretchers, folding chairs, folding tables, collapsible trays, a bench, a clip, expandable batons, and suitcase handles because they contain design elements such as the use of a tension rod means to provide structural support in an extended position.

[206] Dr. Brienza said he would limit the CGK to mobility aiding devices because they operate in a unique and dynamic environment in which the device has to provide support for the user when pushing it while walking, as well as support, and stability to the user when they sit on it. In addition, the user must be able to fold the device when desired.

[207] Dr. Brienza's opinion was that static devices such as a bench or a clip for a baton would not assist the POSITA nor would other devices such as a collapsible tray because they are not structured to operate in the same dynamic environment as a mobility aiding device.

[208] Mr. Schuch would cast a wider net for CGK on the basis that a lot of everyday items have a long history and many mechanical devices — including folding tables and chairs — incorporate elements such as tension rod means and cross braces to provide structural stability and to distribute weight or loads.

[209] Both experts agree that the wheelchair, one of the original mobility aiding devices, has been around for a long time and the basic principles of design and construction for mobility aiding devices are well understood by persons in the field.

[210] I accept Dr. Brienza's analysis of the dynamic nature of the operation of a mobility aiding device and that it presents unique design challenges that are not common in everyday devices or structures. The impact of any design modification therefore needs to be assessed for usability in a variety of environments.

[211] Evolution suggests that Dr. Brienza was not consistent in his statements about non-mobility aiding objects not being part of the CGK and that he contradicted himself when, as one example he referred to a door hinge. I do not view his evidence in that light. Dr. Brienza drew a distinction between what an inventor would consider and what would be the CGK of the POSITA. As such, it was his opinion that non-mobility aiding objects would not be part of the CGK of the POSITA. Without a doubt, hinges are found in many mobility aiding devices and in that respect form part of the CGK.

[212] An understanding of the concepts and principles, the purpose and use of the elements of a mobility aiding device such as tension rods, beams, cross braces, struts, and hinges would be part of the CGK. Similarly other mobility aiding devices that fold for storage would also form part of the CGK.

[213] However, given the complexity of the design process and the risk of harm to a user if the design is faulty, the CGK would not include the knowledge of everyday structures and elements of long standing objects that are not related to mobility aiding devices. Those elements of the CGK upon which the experts agree, as set out above, would be part of the CGK of the POSITA.

[214] Finally, in describing the POSITA, the experts referred to the POSITA as having an understanding of the needs of the population for whom the product is intended and knowledge of the materials to use for particular design purposes. That knowledge would be part of their CGK. It also persuades me that straying too far outside of the field of mobility aiding devices to look for elements present in other structures would not be part of the CGK.

E. *The Essential Elements of the Claims in the 392 Patent*

[215] An element is essential if it is required for the device to work as contemplated and claimed. It is non-essential if it may be substituted or omitted without having a material effect on either the structure or operation of the invention described in the claims. However, an element can be essential in spite of it being substitutable or omittable if it is clear from the specifications, without the consideration of extrinsic evidence, that the inventor(s) intended it to be essential: *Free World Trust*, at paras 20 and 31(e)(iv).

[216] A purposive construction of the claims is required in order to determine which elements are essential. To that end, the Supreme Court provides the following guidance:

For an element to be considered non-essential and thus substitutable, it must be shown either (i) that on a purposive construction of the words of the claim it was clearly not [emphasis added] intended to be essential, or (ii) that at the date of publication of the patent, the skilled addressees would have appreciated that a particular element could be substituted without affecting the working of the invention, i.e. had the skilled worker at that time been told of both the element specified in the claim and the variant and “asked whether the variant would obviously work in the same way,” the answer would be yes: *Improver Corp. v. Remington*, supra, at p. 192. In this context, I think “work in the same way” should be taken for our purposes as meaning that the variant (or component) would perform substantially the same function in substantially the same way to obtain substantially the same result.

Free World Trust, at para 55

[217] Evolution submits that there are no non-essential terms and the experts have not identified any. They state that although the experts agree on most essential elements, seven elements are in dispute, including one that has been added:

1. Tension rod means;
2. Tension rod “structurally interconnects” supports;
3. Handle extending through the seat/1st support;
4. Handle connected to/directly engaging the tension rod;
5. Cross braces;
6. Pivotal connection between supports and frame members; and
7. First support and second support.

[218] Human Care indicates that the areas of disagreement between the parties include the supports, tension rod means, cross braces and handle. That is not a disagreement with the list provided by Evolution. As will be seen, three of the elements are considered in two different ways.

(1) Essential Elements Agreed Upon

[219] Dr. Brienza and Mr. Schuch agree on the POSITA's interpretation of all but the seven identified terms and limitations in the 392 Patent.

(2) Essential Elements Disagreed Upon

[220] On the basis that they have been construed too broadly by Dr. Brienza, Mr. Schuch disagrees with Dr. Brienza's construction of the terms:

“support,”

“structurally interconnecting,”

“handle [...] for pivoting said tension rod into the release position”

[221] In addition, as discussed in the Infringement analysis, Mr. Schuch disagrees with how Dr. Brienza applies his construction of the claims of the 392 Patent to the Xpresso rollator. This is particularly so with respect to the elements “handle,” “tension rod means,” and “cross braces.”

(3) The Approach to a Purposive Construction of the Essential Terms in Dispute

[222] In undertaking a purposive construction of the claims terms in dispute, it is necessary to keep in mind the principles of construction enunciated earlier. It is also necessary to understand both the purpose of the invention and the problem that the invention sought to address: *Wenzel*

Downhole Tools Ltd v National-Oilwell Canada Ltd, 2011 FC 1323 at para 61. In addition, I am mindful that the claims are not to be construed with reference to the prior art: *Whirlpool*, at para 49(a).

[223] The Technical Field and the Background of the Invention sections of the 392 Patent identified two problems to be solved. One was the ability to fold up a mobility aiding device into a storage position. The other was to replace flexible or hammock seats with a solid seat that would enable the mobility aiding device to be easily folded into a storage position.

[224] The other problem identified in the 392 Patent was that the seating surfaces of the existing devices with two-piece seats were constructed with extra wide abutting surfaces between pivoting seat panels which did not always provide sufficient strength for long-term use. The abutting surfaces could pinch body parts or items placed between the abutting surfaces. It was intended to solve those problems by providing “more comfortable seating and a usable supporting surface for other items.”

[225] Considering those problems, the stated object of the 392 Patent was to overcome the shortcomings of existing devices by providing a mobility aiding device “with a solid seating platform made up two pivotally connected sections, with structural re-enforcements, that fold up easily into a storage position.”

[226] The next step is to determine the meaning of the terms in dispute so that the claims can be construed.

(4) Tension Rod Means

[227] A significant amount of time at trial was spent discussing the tension rod means.

[228] Claim 1 includes a tension rod means. Claims 2 to 9 are dependent claims of Claim 1, and therefore, also include a tension rod means. The introductory words of the tension rod means in Claim 1 are:

tension rod means extending between a bottom of the first support and a bottom of the second support for distributing the weight. . .

[229] Claims 16 and 18 contain a description of the tension rod means which is slightly different than the wording in Claim 1 in that the opening words “extending between a bottom of the first support and the bottom of the second support” have been removed:

tension rod means for distributing the weight between the first and second supports, said tension rod means being adjustable between an extended position in which said tension rod structurally interconnects said first and second supports, when the device is in the use position, and a released position enabling the device to be adjusted to the storage position;

[the underlined words are in dispute]

[230] The main point of difference between Dr. Brienza and Mr. Schuch here is whether the POSITA, who has a moderate knowledge and understanding of the design of load bearing structures and mechanical components, would have understood that the definition “tension rod means”, in addition to resisting tensile loading, might also be subject to other forces, such as compression or transverse loading, when the rollator is in the extended or use position.

[231] Tensile loading occurs when forces are applied along the length (longitudinal axis) of an element. The force tries to pull the element apart by stretching or spreading it. Transverse loading is the opposite. It occurs when a force is applied at right angles (perpendicular) to the longitudinal axis of a structural element. Under transverse loading a structural element will tend to shear or bend at which point it introduces tensile and compressive stress and strain in the structural element: Expert Statement of Jonathan Schuch, at para 24.

[232] Mr. Schuch defines a “tension rod” as “a thin straight bar that connects opposite parts in order to prevent their spreading and, consequently, is in tension.” He acknowledges that in the 392 Patent it is shown as a two-piece hinged plate that folds and unfolds as the device is folded or unfolded.

[233] Dr. Brienza noted that the 392 Patent claims a “tension rod means” and that the POSITA would understand the word “means” indicates there are several different ways by which the tension rod could be created including with single or multiple components. He indicated the POSITA would understand that the reference to a tension rod plate is one example of a tension rod means. He stated it could also be in various sizes. However, he noted that the term “rod” would be understood to limit the means in that it could not include a flexible cable or the like.

[234] Paragraph 37 of the disclosure describes the elements of the tension rod:

[37] As best seen in Figure 7, the tension-rod plate 36 is comprised of a first solid link 51 pivotally connected to the bottom surfaces of J-shaped arms 43a, and a second solid link 52 pivotally connected to the bottom surfaces of J-shaped arms 43b. The first and second solid links 51 and 52 are pivotally interconnected by a

hinge 53, which is positioned directly below the first hinge 33 and parallel thereto.

[235] Figure 7 of the 392 Patent depicts a view of the tension rod plate 36 looking up from below the seating platform:

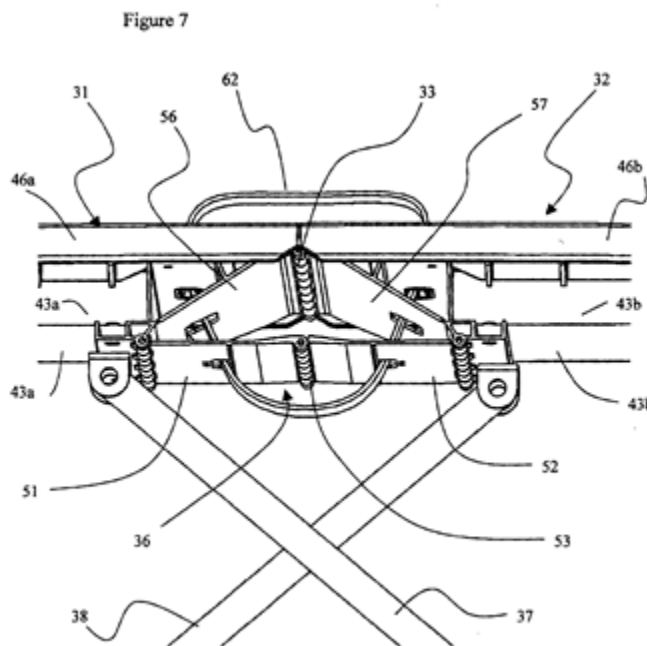

[236] Mr. Schuch says the tension rod means resists a tensile load placed specifically at its ends because it is connected at its outer ends to the overall structure. His opinion is based on there being no structural elements going across the interior of the tension rod plate to provide transverse loading.

[237] Given the use to which a rollator might be put, such as walking on uneven ground, Dr. Brienza opines that other forces could also be exerted. For example, an impact by one of the

wheels with an object could result in a force being applied at an angle. The angle would then result in both vertical and horizontal forces being applied to the tension rod means.

[238] On cross-examination Mr. Schuch stated that there is a vertical force on the tension rod means, but he qualified that by saying it is found only at the outer ends, of the solid links 51 and 52 where it connects with the struts 56 and 57 as shown in Figure 6 of the 392 Patent:

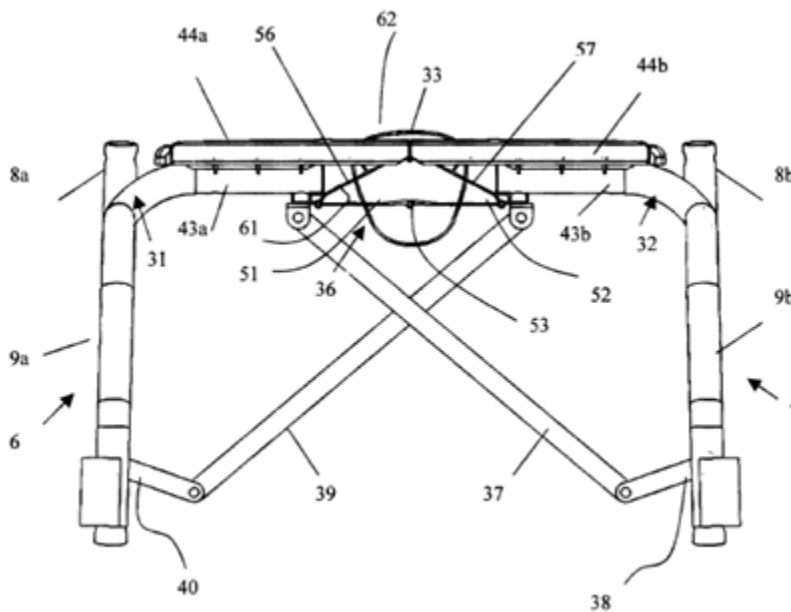

[239] When pressed to agree that there was a transverse load at that connection point, Mr. Schuch said that while there was a vertical load there, it was not transverse loading across the tension rod. Subsequently, he agreed that there was some transverse load at the connection point. He denied that it was a transverse load applied to the tension rod as there was, at that point, what he called “other structure” to take it on.

[240] In his Expert Report, Mr. Schuch says the 392 Patent teaches a specific design and loading mechanism for the tension rod as seen above in Figure 6. When there is a downward pressure on the seat, the load travels through struts 56 and 57 to the outer ends of the links 51 and 52 which are secured to the J-shaped arms and to the cross braces. He says the transfer of the force in this manner results in purely tensile loading of the tension rod.

[241] Dr. Brienza stated that the tension rod, when in the extended or use position, is primarily in tension. Mr. Schuch believes the tension rod of the device described in the 392 Patent is not subject to any transverse forces; it withstands purely tensile loads. Both experts acknowledge that with a beam there is compression on the top surface and tension underneath.

[242] Ultimately, the difference between the two experts on this aspect of the tension rod means is a disagreement over the degree of tension carried by the tension rod means and whether it is subject to resisting any compressive forces.

[243] I am satisfied that given the environment in which a rollator operates, it will be subject to a variety of forces including both tensile and transverse forces. A mobility aiding device whether navigating outside or indoors faces the distinct possibility that the rollator would knock into walls, doors, rocks or other obstacles while travelling through narrow spaces, around objects or over uneven ground. Such impacts would cause forces to be applied at a variety of angles other than purely vertically or horizontally.

(5) Tension Rod Structurally Interconnects

[244] The experts disagree on the meaning of the term “structurally interconnects,” as it is used in connection with the tension rod means in Claims 1-9 and Claims 16-18.

[245] Dr. Brienza stated that the POSITA would have understood that the tension rod means “structurally interconnects” the supports by resisting a pulling force when the device is in the use position. His opinion was that it would have been understood that the tension rod means interconnects or joins together the supports in a structurally sound manner when in the use position. At that time it is fully extended and is “as long as it’s going to get” even though forces applied to it are trying to extend it. As the tension rod is rigid it cannot extend further and it effectively holds together the supports. Dr. Brienza explained at trial that “by hold together, I mean preventing it from collapsing further.”

[246] During cross-examination it was put to Dr. Brienza that “there is no structural limitation to what the tension rod means could or could not be.” In response he identified that the claim is that the tension rod means is for distributing the weight between the first and second supports and there is only one limitation. The claim only talks about doing one thing, which is to hold the bottoms of the supports together and prevent the seat from collapsing when a person sits on it.

[247] Dr. Brienza states that in Claims 16 and 18 the term “structurally interconnects” describes what the tension rod means does to the supports. It does not describe either where the tension rod means is located or how it is connected to the supports. Dr. Brienza contrasts this to Claim 1

where the location of the tension rod means is stipulated as “extending between a bottom of the first support and a bottom of the second support.”

[248] Dr. Brienza concludes that since the type of connection of the tension rod means and the supports is not specified in the claims, the structural interconnection could be either direct or indirect and could involve one piece or multiple pieces — as long as it performs the function of distributing the weight and is subject to the limitation that it holds the bottoms of the supports together to prevent the seat from collapsing when a weight is placed on it.

[249] Mr. Schuch agrees with Dr. Brienza that in the term “structurally interconnects” the word “interconnects” means “joins together.” He agrees that as Claim 16 differs from Claim 1 the tension rod means could extend between the two supports other than at their bottom portions. However, because the limitation is that the tension rod means distributes the weight between the two supports and structurally interconnects them, Mr. Schuch construes it to mean the tension rod means is directly connected to both supports and extends between them.

[250] As will be seen in the next section, Mr. Schuch construes the support as the J-shaped arms and sleeves to which they are attached. Dr. Brienza construes it differently. As the tension rod structurally interconnects the supports, this important difference affects their respective interpretations of the element “the tension rod structurally interconnects.”

[251] In his Rebuttal Report, Mr. Schuch challenges Dr. Brienza's construction on the basis that including a direct or indirect interconnection that could involve one piece or multiple pieces is virtually limitless and overly broad. Mr. Schuch says:

. . . the 392 Patent . . . describes and illustrates a device having two supports directly connected by a tension rod means. No alternative embodiments are described or suggested, and the 392 Patent contains nothing to suggest the connection of the two supports by the tension rod means could be indirect.

Schuch Rebuttal Report, at para 13.

[252] Evolution submits that Mr. Schuch's interpretation is to be preferred because the 392 Patent describes and illustrates a single structural design which is a tension rod that is directly connected to both supports and extends from one to the other.

[253] At trial, Dr. Brienza explained that in order to determine whether any two components do indirectly "structurally interconnect" each other within the meaning of Claims 16 and 18 he would first need to know what the connection was trying to prevent or accomplish, such as "for distributing the weight" in Claims 16 and 18. In Dr. Brienza's view, it is the additional information in the claim that adds the necessary clarity to the term "structurally interconnects." He also confirmed that the term "structurally interconnects" relates only to the "tension rod means."

[254] Evolution put forward the proposition that Human Care "agreed" that Dr. Brienza's terminology with respect to "directly interconnect" was "vague and/or ambiguous;" and therefore the usefulness of Dr. Brienza as an expert was undermined.

[255] This allegation by Evolution is not accurate. The “agreement” in question upon which Evolution relied was a response by Human Care to several questions posed by Evolution, pre-trial, in its Request to Admit. Evolution sought agreement to the proposition that the 392 Patent describes “a tension rod plate directly interconnecting the bottom surfaces of the “first support” and “second support” of the rollator.” Several variations of the question were posed.

[256] At no point did Human Care agree with the proposition or any variation of it. A review of the Responses to the Request to Admit shows the answers by Human Care that it was “vague and/or ambiguous” referred not to any statement or terminology related to construction of the 392 Patent. Human Care was referring to the question which was posed. The answers also included that it was subject to expert opinion.

[257] I am satisfied based on the wording of the question and the answer that Human Care did not agree to anything. In addition, the answer provided is correct given that the phrase “directly interconnecting” posed in the request does not exist in the 392 Patent.

[258] Having reviewed the expert reports and upon considering the evidence given at trial, as well as the language of the claims in the 392 Patent, I favour Dr. Brienza's interpretation. The language of Claims 16 and 18 does not require the tension rod to directly interconnect to the supports. To conclude otherwise would ignore the language employed by Claims 16 and 18.

[259] Mr. Schuch did not take into consideration the specific language used in the claims which is not “tension rod” but rather “tension rod means.” Although he refers to the phrase “tension rod

means,” there is no indication that Mr. Schuch differentiated it from his own definition of a tension rod as a thin straight bar. He did not address how the POSITA would have understood the use of the word “means” nor did he refute Dr. Brienza’s interpretation of “means” as indicating that there are several different ways by which the tension rod could be created.

[260] In effect, Mr. Schuch read out the word “means” when he justified his critique of Dr. Brienza’s interpretation of either a direct or indirect connection involving one or multiple pieces by stating that “no alternative embodiments are described or suggested.” In this instance, use of the word “means” specifically suggests that other embodiments are possible.

[261] In *Whirlpool*, at paragraphs 52-53, Mr. Justice Binnie expressed his concerns with the strict dictionary or grammarian approach to purposive construction. He perceived two difficulties:

- (1) rather than looking in the dictionary to determine what a term or element means one is to look at the specification to see the sense in which the patentees have used it, to ascertain the nature of the invention but not to permit the patentee to expand his monopoly, as described in the claims, by borrowing from the specifications;
- (2) a dictionary approach urges consideration of the words through the eyes of a grammarian or etymologist rather than through the eyes of a worker of ordinary skill in the field possessing the common general knowledge of such a person.

[262] Addressing the ability of the skilled worker, Mr. Justice Binnie added that the skilled worker is an individual “sufficiently versed in the art to which the patent relates, to enable them on a technical level to appreciate the nature and description of the invention.” The skilled

worker, by using their common knowledge, is to make sense and purpose of the words used in the claim: *Whirlpool*, at para 53.

[263] Keeping these principles in mind and on considering the evidence, I prefer the interpretation of Dr. Brienza. It not only preserves the language of the claims but also respects the principle of claim differentiation. In Claims 16 and 18, the location of the “tension rod means” is not specified but in Claims 1-9 it extends “between a bottom of the first support and a bottom of the second support.” Dr. Brienza put forward an interpretation that respects and gives meaning to that different claim language.

[264] As to the argument that Dr. Brienza’s interpretation results in a virtually limitless set of possible connections from the tension rod to a multitude of intermediary parts which subsequently connect to the supports, the same interpretive problem arises. I disagree that Dr. Brienza’s interpretation encompasses virtually limitless connections and pieces. The specification provides the limitation that the “tension rod means” is required to distribute weight between the two supports and it is to be adjustable between the use in the storage position.

[265] Mr. Schuch again argues that there are no alternative embodiments to suggest an indirect connection. He provides examples of a tension rod in the interior roof of a house and in the front suspension of a Chrysler 300C to illustrate that those tension rods do not structurally interconnect other parts. Those examples, which I accept contain tension rods, do not assist in construing the claims of the 392 Patent. The 392 Patent is the primary interpretative aid in construing its claims. The contexts of these examples are so disparate from the context of the

392 Patent that they are of little interpretative value. Regardless, these examples would not form part of the POSITA's CGK.

[266] Evolution also argued that Dr. Brienza read out the plain and unambiguous structural limitation in favour of a purely functional interpretation when he said that the term "structurally interconnects" describes what the tension rod means does rather than where it is or how it is connected to the supports. Evolution is correct, that the term "structurally interconnects" in Claims 16 and 18 does describe the function of the tension rod means rather than its location. However, this interpretation respects the drafter's intention in accordance with the principles of purposive claims construction. Claim 1 specifies the location of the tension rod means and Claims 16 and 18 do not. Thus, the term "tension rod means" is properly interpreted as location independent in Claims 16 and 18.

(6) First and Second Supports

[267] The detailed description and the claims in the 392 Patent specification refer multiple times to a first support and/or a second support. All the independent Claims being 1, 10, 12, 14-18, use the same language and claim the same supports:

a first support pivotally connected to the first frame member;

a second support pivotally connected to the second frame member and pivotally connected to the first support, the first and second supports for supporting the weight above the ground in the use position;

[268] The experts disagree as to which components are included as part of the first and second supports. They also have different views about how the “hinge means” is understood in relation to the supports, specifically to whether the seat cover is part of the supports.

[269] The understanding of the “hinge means” is an integral part of the disagreement over the component parts that together make up the “first and second support.” There are three different descriptions of the “hinge means”:

In claim 1 the hinge means is “pivotally connecting a top of the first support to a top of the second support”;

In claims 10, 12, 14 and 15 a “first hinge means” is “pivotally connecting upper portions of the first and second supports”;

In claims 16 - 18 there is a “hinge means pivotally connecting the first support to the second support.”

[my emphasis]

[270] Dr. Brienza interprets the hinge means as being the device for holding together the supports so that they can rotate (fold) relative to each other. Because of the word “means” the POSITA would understand that there may be different ways to create the hinge. The limitation is that the hinge means has to allow the two supports to rotate with respect to one another so that they can transition from a use position to a folding position.

[271] In his Expert Report, Mr. Schuch disagrees with Dr. Brienza’s construction of the term “support” believing it to be too broad because Dr. Brienza included the two halves of the flat seating platform (44a and 44b) and the foam seat cover (46a and 46b). Mr. Schuch’s construction

of “support” would stop at the structure underneath the seating platform — the sleeves (42a and 44b) and the J-shaped arms (43a and 43b) as being the structure that supports the seat.

[272] Subsequently, in his Rebuttal Report, Mr. Schuch decided that Dr. Brienza’s construction was “within the range of reasonable construction that could be adopted by the POSITA.”

Mr. Schuch came to this conclusion as he found the patent was ambiguous and “does not clearly describe whether the two flat seating platforms (44a, 44b) or the separate foam seat cover are intended to also be considered part of the first and second supports.”

[273] During cross-examination, however, Mr. Schuch stated that his own construction was to be preferred because it worked with the whole patent. He reasoned that Dr. Brienza’s interpretation would invalidate “the first nine or very likely the first 15 claims” because they state the first hinge means pivotally connects the upper portions of the first and second supports. Since Dr. Brienza’s construction places a seat cover over the hinge, Mr. Schuch reasoned that once the seat cover is on top of the hinge, there is no hinge at the top of the supports.

[274] Human Care believes that Mr. Schuch’s construction is based on a single sentence in paragraph 36 of the patent description which reads:

The right side support 3l includes a sleeve 42a surrounding the horizontal portion of the L-shaped bar 9a, and a part of J-shaped arms 43a extending therefrom for supporting a flat seating platform 44a.

[275] Human Care points out that Mr. Schuch’s construction does not consider the very next sentence in the description which reads:

Similarly, the left side support 32 includes a sleeve 42b surrounding the horizontal portion of the L-shaped bar 9b, and part of J-shaped arms 43b extending therefrom for supporting a flat seating platform 44b. A foam seat cover is placed over the flat seating platforms 44a and 44b covering the hinge 33.

[276] Mr. Schuch confirmed during cross-examination that his construction was not aligned with the figures of the 392 Patent because “what’s shown in the figures also, then, develops conflict with those first 9 claims with a hinge located beneath the seat cushion and beneath some of these other structures given Dr. Brienza’s interpretation.” He also confirmed that some of the drawings show a handle going through other parts that he would not interpret as the support.

[277] Mr. Schuch argued that because the first several claims state the “hinge means” connects “a top” of the “supports,” these claims would be invalidated under Dr. Brienza’s construction because they would not work when the hinge is placed on the foam seat cover.

[278] Dr. Brienza’s interpretation of the seat cover being part of the supports includes his understanding that the POSITA, having moderate knowledge and understanding of the selection of materials to achieve design goals, would understand that one cannot put a hinge on a foam seat cover . I find that the answer to Mr. Schuch’s concern that the seat cover would prevent the device from working is located in paragraph 36 which specifically contemplates that a foam seat cover would be placed over the hinge to prevent pinching:

A foam seat cover is placed over the flat seating platforms 44a and 44b covering the hinge 33. The seat cover can be made from two separate pieces 46a and 46b or from a single piece of foam-like material with a particularly flexible section covering the hinge 33. The flexible section could include several grooves extending thereacross to provide the required flexibility. Since the seat cover

pieces 45a and 46b are made of foam, any accidental pinching therebetween will not result in any pain.

[279] Paragraph 36 stipulates that a flexible section of the seat cover would cover the hinge. An example of the flexible section is given in that it could include several grooves to provide the required flexibility. Given that construction of the seat cover, the device will still easily fold into a storage position when it is placed over the hinge.

[280] Considering the evidence before me and noting the specific reference to placing a seat cover over the hinge, the language in the 392 Patent does not support Mr. Schuch's analysis.

[281] Dr. Brienza's construction is consistent with the language of the 392 Patent. I find that the first and second supports include the sleeves 42a and 42b, the J-shaped arms 43a and 43b, the flat seating platform 44a and 44b, and the foam seat cover 46a and 46b.

(7) Handle

[282] The only difference between Claims 16 and 18 is that Claim 18 does not include cross braces extending between the supports and frame members and, it adds a handle element:

a handle extending through said first support for pivoting said tension rod into the release position, and for pivoting said first and second supports into the storage position.

[283] The nub of the disagreement between Dr. Brienza and Mr. Schuch is whether the handle must directly cause the supports to pivot toward one another.

[284] Dr. Brienza stated that the handle serves two purposes: (1) for pivoting the tension rod into the release position; and (2) for pivoting the first and second supports into the storage position.

[285] Some detail is given in the specification about the nature of the handle in that it extends through the first support. Dr. Brienza said that the POSITA would understand that “extending through” the support means the handle is above the support and below it and it gets from “above” to “below” by passing through the support. He found it more relevant though to look at why the handle needs to be above the first support which is because that is where the person who needs to operate the handle is located. The person would not want to have to reach underneath the seat where they might be subjected to issues such as pinching.

[286] Mr. Schuch challenged Dr. Brienza’s construction for being overly broad because it would encompass any handle that could accomplish the desired result without limiting it to the specific mechanisms and means described in the 392 Patent.

[287] In terms of how the handle would be connected to the tension rod means or the supports, Dr. Brienza opined that because the handle passes through the first support it is connected to something or, perhaps it is looped around something, in order to resist an upward force.

[288] In the embodiment shown in Figure 7 of the 392 Patent, the handle passes through each of the supports, the struts and the holes in the “tension rod means” so that it forms a loop. Pulling on the handle would cause the loop to contact the central portion of the tension rod means which,

with the application of an upward force, would cause it to pivot at the hinge between the two links of the tension rod means. Then, because of the interconnections with the frame, it would cause the entire frame to enter the folding configuration.

[289] Dr. Brienza stated that the handle could extend through the first support by a variety of means such as a hole or knot or the removal of material from the first support. As long as it was accessible from above the first support and could be used to cause the tension rod means below the supports to transform, it could also extend through other parts of the device.

[290] Dr. Brienza noted that the first and second supports do not directly interact with the handle other than rubbing on the edges of the holes in each support as it passes through them. The first and second supports move with the bending (folding) of the tension rod means because of their relation to the rest of the frame of the rollator. When one of the supports moves, the other will move as well because of the way the frame is configured.

[291] Mr. Schuch disagreed with Dr. Brienza's construction of the first and second supports but he agreed during cross-examination that if the two seat covers are part of the supports (as per Dr. Brienza's interpretation) then he would not have an issue concerning how the handle passes through the supports. However, he would have an issue with what the handle does as it passes through the supports.

[292] As I have determined that the seat covers are part of the supports, the only issue to resolve with respect to the handle is whether the 392 Patent claims describe what the handle

does. This requires examining (1) how the handle engages the tension rod means to pivot it into the release position; and, (2) how the handle pivots the first and second supports into a storage position.

[293] As to how the handle engages the tension rod, Mr. Schuch explains in his Expert Statement the reason he believes there must be a direct connection between them:

The only means disclosed in the specification and drawings for accomplishing these purposes is to engage the tension rod and unlock it (i.e. cause the lower links of the tension plate to fold upward in the middle). The handle in Claim 18 is therefore construed to encompass a handle that engages with some portion of the tension rod (either the two links or the hinge joining them) and pull it upward into the unlocked position, allowing the device to be folded.

Expert Statement of Jonathon Schuch, at 42.

[294] Mr. Schuch explained during cross-examination that he placed the limitation of a direct connection on the handle element because paragraph 39 of the specification says that the handle “is used to manually pull up on the tension-rod plate” and “initial force pulling up on the strap disengages the locking feature and pivots the tension rod plate enabling the right and left supports to pivot towards each other.”

[295] Mr. Schuch then explained that as a result of the language in paragraph 39 of the specifications his interpretation was that “the handle is used to and therefore needs to manually pull up on the tension rod plate because that’s what’s described. That’s the mechanism by which the patent teaches me to fold the tension rod.” I have underlined words added by Mr. Schuch to the language of paragraph 39.

[296] Mr. Schuch does allow that under his interpretation it does not matter where or how the handle connects to the tension rod means as long as it is used to manually pull up on the tension rod plate to pivot it. He was satisfied that if the handle did not loop underneath the tension rod, it also did not have to be in the same orientation or configuration as shown in the preferred embodiment. The handle could be attached to the hinge in the middle of the two links or to the top of the two links.

[297] Claim 18 says simply that the handle is for pivoting the tension rod into the release position. Mr. Schuch is concerned that the purpose of the handle is described but the means by which it accomplishes that purpose is not described. In his opinion that lack of detail allowed for a wide variety of means to accomplish the purpose, ranging from a lever to a spring and even, as he put it, a Rube Goldberg design which he noted was an exaggeration.

[298] Mr. Schuch said that the way the claim is written he could not understand what it was teaching him. His conclusion was that nothing was taught unless the handle was construed as manually pulling up on the tension rod plate.

[299] During cross-examination, Mr. Schuch agreed that pulling on the handle did not directly cause the first and second supports to pivot toward one another. The handle causing the “tension rod means” to fold is what resulted in pivoting the supports.

[300] Mr. Schuch agreed that in order to break the tension to be able to pivot the tension rod upward the handle could have been indirectly connected through, for example, a lever but, it is

not described in the patent. He opined that such a construction would open the door to “any and all structural means” to accomplish the purpose; a variety of structural options or mechanical part options would meet the language.

[301] I find Mr. Schuch’s construction of the handle does not take into consideration the description of the handle in Claim 8:

. . . said handle extends from said first link through said first support, back through said second support to said second link, whereby pulling on said handle pivots said first and second links and said first and second supports towards each other into the storage position

[302] In Claim 8 “pulling on said handle” describes a direct action and connection to pivot the first and second links which are the equivalent of the tension rod means. In order to respect the principle of claim differentiation the phrase “for pivoting said tension rod” in Claim 18 is to be contrasted with the phrase in Claim 8 “whereby pulling on said handle pivots . . .”

[303] As the reference to the term “handle” is different in each of Claims 8 and 18 a different meaning must be ascribed to it in each claim. Mr. Schuch failed to do this. Dr. Brienza recognized the principle and applied it appropriately when considering the language differences between the two claims. “For pivoting” could be a direct or indirect connection whereas “pulling on said handle” can only be a direct connection.

[304] It is also important to keep in mind that the object of the invention is a mobility aiding device, with a solid security platform made up of two pivotally connected sections, with

structural reinforcements, that folds up easily into a storage position. Being able to fold easily is one of the primary obstacles identified in the prior art that the invention claims to overcome.

[305] Dr. Brienza said the POSITA would understand that by pulling up on the handle it caused the tension rod to transform into its released position by rotating at its hinged joint. He observed that it was not specified how the handle would interact with the supports but that however it did, it would also cause them to start to transform into a storage position. He said the POSITA understands basic mechanics and would understand how the handle would interact with components such as the tension rod or the supports to enable the device to fold. An example he gave was that the person could just pull up directly on the tension rod and not use the handle.

[306] Evolution maintains, as did Mr. Schuch, that on reading through the patent that the POSITA would understand there is one mechanism described for pivoting the tension rod and for pivoting the supports – pull up on the handle. The handle pivots the tension rod, the tension rod is attached to the supports and pulls them together. Evolution submits that is the only mechanism disclosed.

[307] Mr. Schuch states that Dr. Brienza construed the term “extending through said [...] supports” without considering the purpose of the claim element which Mr. Schuch says is to allow the handle to connect to the components underneath the seat which means to specifically act upon one or both links of the tension rod means.

[308] I find that the purpose of the handle in Claim 18 is to go through the first support to cause the device to fold and enter the storage position. The POSITA with the CGK, particularly their knowledge of other folding mobility aiding devices, would understand that whether the handle accomplishes that purpose directly or indirectly, it interacts with the components below the seat to pivot the tension rod into the release position and to pivot the first and second supports into the storage position resulting in the device folding. The reference to pivoting, which is folding, provides a structural limitation to assist the POSITA to understand the various ways in which the handle could interact with the components to accomplish the purpose. A further limitation on the handle is that it is accessed from above the seat.

(8) First and Second Cross Braces

[309] Claims 3, 15 and 16 refer to cross braces. Claim 16, shown below, presents the elements in separate clauses while Claims 3 and 15 have them combined as one clause. The wording is identical in all three claims:

a first cross brace extending between the first support and the second frame member for transferring at least a portion of the weight to the second frame member; and

a second cross brace extending between the second support and the first frame member for transferring at least a portion of the weight to the first frame member

[310] The dispute between the two experts is about the meaning of “extending between” and whether or not the two cross braces each require a direct connection from a support to the opposite frame member.

[311] The cross braces are described in the latter part of paragraph 35 of the 392 Patent:

Additional support for the seating structure 10 is provided by a first cross brace 37 extending from the bottom surface of the right side support platform 31 to a first finger bracket 38 fixed to the crossbar 11b, and a second crossbar 39 extending from the bottom surface of the left side support platform 32 to a second finger bracket 40 fixed to the crossbar 11a. Both ends of the first and second cross braces 37 and 39 are pivotally connected to their respective mounting points.

[312] Mr. Schuch construes the cross braces as having a direct connection to the supports. He notes that they contain “a transverse part that transmits, diverts, or resists force/load” from a first or second support “for diverting some or all of the weight” to the second or first frame member.

[313] Dr. Brienza’s construction is essentially the same as to how the cross braces work. He adds that the weight referred to would be the weight of the user as well as of the device. He also adds that the term “at least” means all or some fraction of the weight.

[314] Where Dr. Brienza differs from Mr. Schuch is that as the claim does not specify the cross braces are connected to the supports and to the frame members they could be connected directly or indirectly. They could also be achieved by a variety of means such as via one or more components.

[315] The disagreement between Mr. Schuch and Dr. Brienza is not really about cross braces. Mr. Schuch and Dr. Brienza agree on what the cross braces are and what they do. The dispute is whether the cross braces, which each attach to a finger bracket that is in turn attached to a cross

bar, is a direct or indirect connection. The overall disagreement was couched in what “extending between” means.

[316] In his two reports, Mr. Schuch did not identify the finger brackets as being part of the frame member but he did so at trial because they are fixedly attached to the frame and, the purpose of the cross braces is to transfer at least a portion of the weight to the frame member.

[317] Human Care submits that by taking that position, Mr. Schuch contradicted his previous interpretation that the seating platform was not part of the supports, even though they are fixedly attached to the J-shaped arms.

[318] On cross-examination, Mr. Schuch agreed with the proposition that being fixedly attached does not automatically make such part an element of a component:

Q. I take it from your answer that you would agree, then, that simply being fixedly attached to something does not in [and] of itself automatically make that part an element of a component in this patent, then?

A. It would seem to me that before one would say that something fixedly attached becomes a part of, one would have to look at greater -- look at the detail behind that connection and look at the language describing the connection and the parts.

Q. Fair to say that the context, then, is important? That, as a rule, you can't simply say because it's fixedly attached it is or isn't part of the element, it's the broader context that's important?

A. Yes, I think generally the context and purpose and the overall description is important.

Trial Transcript Vol 7, P 1254, L 18-18; P 1255, L1 - 4.

[319] Evolution submitted that Mr. Macmillan, when he was shown CAD drawings of the side frames at trial, agreed that the finger bracket was part of the side frame member. I am not prepared to give that part of Mr. Macmillan's evidence much weight, if any. Mr. Macmillan in general qualified his skills as "I'm not a trained engineer, I am not a designer. I am just a simple sales and marketing guy."

[320] Asking Mr. Macmillan to interpret a CAD drawing and provide or confirm a conclusion upon which the Court may rely is not realistic. All the more so when it is considered in the context that the two expert engineers in this matter cannot agree on the answer. I am sure he will not be offended when I say that Mr. Macmillan is not qualified to be the tiebreaker.

[321] Dr. Brienza notes the purpose of the cross braces as set out in Claim 16 is to transfer "at least some of the weight" from the first or second support to the second or first frame member, as the case may be.

[322] Evolution submits that during cross-examination, Dr. Brienza admitted that he did not know whether the POSITA would decide that the finger bracket is or is not part of the frame member. I have reviewed the transcript. The conversation was quite brief. Dr. Brienza specifically says the POSITA would have said that the finger bracket was not part of the side frame: Trial Transcript, Vol. 3, P. 549, L 3-22.

[323] When discussing the tension rod means and the J-shaped arms with counsel for Human Care, Mr. Schuch said that:

Q. So just so I am clear, you view if it's fixedly attached to be, as terms that we have been using in this litigation, directly connected as opposed to indirectly connected?

A. Yes. So structurally that is in essence, in my view, a direct connection.

Trial Transcript, Vol. 7, P. 1252, L 9 – 14.

[324] When Human Care pointed out to Mr. Schuch that previously he did not include the seating platform as part of the supports even though they were fixedly attached to the J-shaped arms, he defended his answer on the basis that it was somewhat different than describing a bracket because there was other language. He then agreed that just because something is fixedly attached one cannot say it is or is not part of an element because “generally the context and purpose and overall description is important.”

[325] I am not persuaded in this instance or others which have arisen in the course of this matter that statements such as, for example, “[a]dopting a construction which permits connections to be indirect renders the structural limitation “extending between” meaningless as it would allow the cross braces to be placed anywhere on the structure.” This discounts both other limitations in the claim, an important one being that the cross braces must transfer at least a portion of weight of the support to the frame member. It also ignores the fact that the claims are to be construed in light of the patent as a whole including where necessary reference to the specification to confirm an understanding. Mr. Schuch did allow during cross-examination that

context is important and one has to look at the detail behind a connection as well as consider the language used.

[326] Considering that:

- the broad language used in Claim 16 which does not call for a connection but rather uses the less precise language of “extending between”;
- the fact that Mr. Schuch initially did not include the finger bracket as part of the frame in his two reports;
- his acknowledgement that the finger brackets are not in the same plane as the frame nor are they claimed in the 392 Patent to be part of the frame member; and
- Dr. Brienza’s analysis in which, contrary to Evolution’s suggestion, he clearly stated the POSITA would not find the finger bracket to be part of the frame member.

I am comfortable in finding that the cross braces do not attach directly to the frame member.

They are indirectly attached to it which, in the preferred embodiment, is by way of the finger brackets.

[327] After construing the elements of the claims, I agree with the parties that these elements are essential. In light of the CGK, it would have been obvious to the POSITA that varying these elements would change the way the invention works. Thus, these elements are essential: *Halford v Seed Hawk Inc*, 2006 FCA 271 at para 13 [*Halford*].

VIII. **Infringement**

A. *The Law*

[328] The right to take action against a party that has infringed a presumptively valid patent is found in the *Patent Act*. Section 42 grants the patentee and their legal representatives the

exclusive right, privilege and liberty of making, constructing and using the invention and selling it to others. Subsection 55(1) then provides that a person who infringes a patent is liable for all damages sustained by the patentee by reason of the infringement.

[329] The burden of proving infringement is on the party that alleges it – in this case Human Care: *Monsanto Canada Inc v Schmeiser*, 2004 SCC 34 at para 29 [*Schmeiser*].

[330] Whether infringement has occurred involves determining whether “the accused device takes all of the essential elements of the invention”: *Free World Trust*, at para 68.

[331] Determining whether infringement has occurred is a question of mixed fact and law. Once the claims have been construed the next step is to determine whether, on the facts, any of the claims have been infringed: *ABB Technology AG v Hyundai Heavy Industries Co, Ltd*, 2015 FCA 181 at para 30 and cases cited therein.

[332] Infringement is defined by reference to the claims, not the invention. If the Xpresso rollator is found to infringe Claim 16 or Claim 18, then all Xpresso rollators will infringe as Evolution agrees that they are all the same with differences only in size.

B. *General Comments on the Infringement Issues between the Parties*

[333] In *Free Word Trust*, there was a lengthy discussion about the difference between “substantive infringement” and “literal infringement.” The conclusion was that what was once a two-step process of inquiry has been replaced by the single step of purposive construction. Even

so, Mr. Justice Binnie allowed that the outcome, after a purposive analysis of the claims, may be the same as would have occurred under the two-step approach:

50 I do not suggest that the two-stage approach necessarily ends at a different destination than the one-stage approach, or that the two-stage approach has resulted in abuse. I think we should now recognize, however, that the greater the level of discretion left to courts to peer below the language of the claims in a search for “the spirit of the invention,” the less the claims can perform their public notice function, and the greater the resulting level of unwelcome uncertainty and unpredictability. “Purposive construction” does away with the first step of purely literal interpretation but disciplines the scope of “substantive” claims construction in the interest of fairness to both the patentee and the public.

[334] In a purposive analysis the Court identifies the particular words or phrases in the claims that describe the essential elements of the invention from the position of the POSITA.

[335] For an element to be found to be non-essential, a purposive construction must show it was clearly not intended to be essential or, it may be found that a POSITA reading the claim at the date of publication would have understood that the element in question could have been switched out for another without affecting the working of the invention. In other words, if the substituted element “would perform substantially the same function in substantially the same way to obtain substantially the same result” then such element can be deemed non-essential.

(1) The Preferred Embodiment

[336] A recurring theme by Evolution is that the 392 Patent teaches one way or describes one method or depicts one embodiment. I take that point to be that the language used in the claims is

both plain and unambiguous as well as quite narrow. It does not allow for any other interpretation. If the allegedly infringing device is not the “one thing” then it does not infringe.

[337] The fallacy with that argument is that a review of the 392 Patent shows that the patentee intended that the device may be varied in a number of ways. Paragraph 38 of the specification demonstrates this point:

[38] In the illustrated embodiment, the locking feature 61 comprises a spring clip extending from the first solid link 51 and the force transmitting strut 56; however, other locking features are possible including a specially designed hinge, which prevents rotation past the fully opened position (illustrated in Figure 6).

[338] The claims describe a wide variety of possible configurations. There are alternate handle configurations as well as no handle at all. The tension rod means may be replaced by a first and second link means or, it may instead contain either a hinge or a spring clip. In a claim there may be one hinge means or two. Claim 16 contains cross braces while Claim 18 does not. In other words, it is clear that there is not one particular configuration or embodiment envisioned by the 392 Patent. This is consistent with the claims’ language containing “means” which indicates there may be several different ways to reach the desired result.

[339] In *Eli Lilly Canada Inc v Apotex Inc*, 2008 FC 142 Mr. Justice Hughes rejected an argument before him that some of the claims in issue should be limited to only one particular type of treatment. He cited *Dableh v Ontario Hydro*, [1996] 3 FC 751 (FCA) as expressly warning against limiting clear and unambiguous words to a preferred embodiment.

C. *The Xpresso Rollator Infringes the 392 Patent*

[340] The Xpresso rollator embodies all of the essential elements of Claims 16 and 18 of the 392 Patent. Therefore, Evolution has infringed the 392 Patent by making and selling the Xpresso rollator.

[341] The most contentious point between the parties is whether the buttressed beam on the Xpresso works in substantially the same way as the tension rod means in the 392 Patent to obtain substantially the same result.

[342] The simplest explanation of Mr. Schuch's disagreement with Dr. Brienza's interpretation concerning the Xpresso's horizontal "beam" is set out in his Rebuttal Statement:

As discussed earlier in this report, intervening parts cannot be ignored. Specifically, the effect of the intervening lower horizontal "beam" must be considered when analyzing the Xpresso. In this case, the cross braces extend from the seat to the lower horizontal "beam" of the Xpresso walker. The cross braces do not extend to the frame members. Furthermore, the structural and functional characteristics of the beam have to be considered when analyzing the transfer of forces from the seat. When weight is applied to the seat of the Xpresso walker, the force acts to collapse the seat downward. However, the cross braces extend from the seat to the beam, which has the buttressed stop previously described and depicted. The weight is transferred through the cross braces to the beam, which undergoes transverse loading. The beam is placed in compression along its upper half and in tension along its lower half. The rigidity of the beam elements, the effectiveness of the buttressed stop, and the connection of the beam elements to the side frames all prevent the beam from collapsing. While forces occur where the beam elements connect to the side frames of the Xpresso walker, this is not a simple matter of cross braces extending between the supports and the frame members for transferring at least a portion of the weight to the frame members.

Jonathon Schuch Rebuttal Statement, at para 57

[343] Dr. Brienza explained his construction of how the Xpresso infringes Claim 16 in simple terms on Day 3 of the trial during cross-examination when he was describing the importance of the location of the Xpresso cross braces:

My position with respect to the Xpresso is that, you know, had the Xpresso had a vertical element that contacted that cross piece in the centre, there wouldn't be any tension, there wouldn't be any tensile forces, and it wouldn't fall within the scope.

But as soon as those cross braces' connection points moved away from the centre, it became a tensile force, and then it fell within the scope of the claim, regardless of whatever else that cross piece is doing.

Trial Transcript, Vol. 3, P. 531, L 4 – 12.

[344] A bit later, in the following exchange, Dr. Brienza provided an elaboration of his previous answer:

Q. A beam resisting a downward force with a buttress stop in the middle to keep it from collapsing and that's what keeps the seat from collapsing, is that keeping that seat coplanar in the same way as a tension rod means actually interconnecting the bottoms of the supports?

A. The difference I see is that that element is doing it in two ways versus a device that was not acting as a tension rod that's not subjected to transverse force. . . . if the connection was in the middle, it would be completely transverse and clearly not fall within the scope of the claim. And if it were all the way on the edge, it would be -- there would be no transverse force from the seat, and then it would very clearly fall within the scope of the claim. So here we are in the middle. So, you know, it's doing both. And is it falling or not? But if you just look at the claim, it doesn't talk about any what else it does. It just talks about that it does that one thing, you know, helping to hold the bottoms of the supports together through tension.

Q. Through tension?

A. And so that's what drives my opinion, that this falls within the scope of the claim, even though I readily admit this is also acting as a beam.

Trial Transcript, Vol. 3, P. 533, L 22-28; P. 534, L 1-17.

(1) Tension Rod Means and Tension Rod Means Structurally Interconnects

[345] I find that the term tension rod means in Claims 16 and 18 of the 392 Patent describe Xpresso's horizontal beam. Both Dr. Brienza and Mr. Schuch agree that there are multiple forces acting on the tension rod means of the 392 Patent and on the "beam" of the Xpresso. The 392 Patent and the Xpresso each employ two links hinged together to distribute those forces.

[346] Given the evidence, I am convinced that the horizontal beam of the Xpresso is subject to tensile forces in addition to transverse forces. Furthermore, despite not directly connecting to the supports, the horizontal beam does indirectly connect to the supports. Thus, the tension rod means of Claims 16 and 18 is present in the Xpresso rollator.

(2) First and Second Supports

[347] Whether the first and second supports are pivotally connected to their respective frame members and each other is primarily a disagreement over whether the seating platform (the seats) and seating covers constitute parts of the supports.

[348] Evolution argued that the seats are not part of the supports, and thus the supports in the Xpresso are neither pivotally connected to the frame members nor to each other. Human Care

asserted that the seats are part of the supports, and thus the supports in the Xpresso are pivotally connected to the frame members and each other.

[349] I agree with Human Care that the seats form part of the supports. I find that the pivotally connected supports of Claims 16 and 18 are present in the Xpresso rollator.

(3) Handle

[350] Claim 18 includes the element of a handle which extends through the first support and pivots both the tension rod means and the two supports. Claim 16 does not contain this element.

[351] Evolution argues that the handle on the Xpresso neither passes through a support nor pivots the other components.

[352] Evolution's argument that the Xpresso handle does not pass through a support is predicated on a construction of the term "support" that does not include the seat. I have accepted that the seat and seat cushion is part of the supports. In that respect, the Xpresso's handle does pass through the first support.

[353] Concerning whether the handle pivots other components, Evolution insists that the handle must directly act on the pivoting components to fall within the meaning of a Claim 18 handle. I have rejected this construction of this element and found that the handle may interact indirectly with the pivoting components and still fall within Claim 18. When one applies an extrinsic force

to the Xpresso's handle, the supports pivot toward each other and so does the beam. Therefore the Claim 18 handle is present in the Xpresso rollator.

(4) The First and Second Braces

[354] Claim 16 includes the element of cross braces which extend between the first support and the second frame member and between the second support and the first frame member for transferring at least a portion of the weight to the frame members.

[355] Evolution denies there are any cross braces extending between the support and the frame of the Xpresso.

[356] Evolution maintains that the cross braces each require a direct connection from a support to the opposite frame member. It says that the Xpresso cross braces extend from the seat support to the beam, not to the frame member. It also says that the two halves of the beam are pivotally, not rigidly, attached to the side frame members.

[357] As I construed this element of Claim 16, the cross braces are not required to be attached rigidly and directly to the frame members. By directly connecting to the beam, the Xpresso's cross braces are indirectly distributing the weight from the supports to the frame members.

Therefore the cross braces from Claims 16 and 18 are present in the Xpresso rollator.

[358] All of the essential elements of Claims 16 and 18 of the 392 Patent are present in the Xpresso rollator. By making and selling the Xpresso, Evolution has infringed Human Care's patent.

IX. **Validity**

[359] Once a claim is construed, the interpretation is the same for all purposes; it does not differ as between infringement and validity.

[360] It has been said that the presumption of validity is a weak one as it is stipulated that "it shall, in the absence of evidence to the contrary, be valid": *Abbott Laboratories v Canada (Health)*, 2007 FCA 153 at para 9. Nonetheless, it is a presumption.

[361] Mr. Justice Hughes set out the evidentiary burdens on the parties this way:

There is an onus upon a party alleging invalidity to lead some evidence tending to prove those allegations; if it has done so the Court will determine the matter on the usual civil burden of proof (e.g. *Tye-Sil Corp. Ltd v Diversified Products Corp.* (1991), 35 CPR (3d) 350 at pages 357-359 (FCA)). Once some evidence has been led, the presumption disappears (e. g. *Rubbermaid (Canada) Ltd v Tucker Plastic Products Ltd.* (1972), 8 CPR (2nd) 6 at page 14 (FC)).

Abbvie Corporation v Janssen Inc., 2014 FC 55 at para 108.

[362] In assessing whether the invention was anticipated in the prior art, the Court is to consider whether any one document disclosed and enabled it. In contrast, a claim may be found to be obvious based off a mosaic of prior art that could have been assembled by the POSITA. For

an invention to be obvious, it must be shown that the POSITA would have been led from the mosaic to the invention without a scintilla of ingenuity.

A. *Rulings on the Objections Relevant to the Validity*

[363] On October 30, 2017, counsel for Human Care wrote to the Court to raise its concerns about Evolution's reliance on the Rideout Patent [Rideout] with respect to its anticipation arguments in its written closing submissions. Human Care maintained that during the trial Evolution reassured the Court that it did not wish to raise points about the Rideout regarding anticipation; and therefore, the Court should strike certain paragraphs of Evolution's closing argument.

Evolution asserted that it raised questions about the Rideout only as a result of Dr. Brienza altering his testimony during the hearing. That is, Evolution submits that in his Expert Report Dr. Brienza claimed that the Rideout teaches every essential element of Claim 16 other than a "tension rod means." According to Evolution, Dr. Brienza contradicted his Responding Expert Report during cross-examination when he conceded that a "hinge means" connecting the seat supports was not taught by the Rideout.

[364] Having reviewed the materials and the relevant portions of the transcript, I find that Evolution is proscribed from raising arguments about Rideout anticipating the 392 Patent for two reasons.

[365] First, counsel for Evolution expressly assured the Court that it will not advance arguments based on the Rideout after counsel for Human Care objected that, based on the words of the question being formulated, there was about to be a suggestion that "Rideout is an anticipatory reference": Trial Transcript, Vol. 9, P. 1639, L 13-19.

[366] In response to that concern, counsel for Evolution simply said “no”, as in no it was not where they were going. Human Care counsel double checked and received another “no” from Evolution whereupon I concluded the matter by saying:

Well, they have said that's not the point, so I think we are all satisfied with that.

Trial Transcript, Vol 9, P 1640, L 1-2.

[367] While Evolution provided the above assurance before Dr. Brienza allegedly altered his testimony during cross-examination, it nevertheless indicated to the Court and opposing counsel the scope of Evolution’s reliance on the Rideout. Accordingly, it would be prejudicial to allow Evolution to make different arguments concerning Rideout without having clarified in their oral submissions, made after Dr. Brienza’s testimony and one month prior to the written submissions of October 25, 2017, that they intended to resile from the former position.

[368] Second, I am not persuaded that Dr. Brienza changed his position during cross-examination. Despite lengthy and vigorous cross-examination, after more than an hour of back and forth between counsel and Dr. Brienza the following interchanges persuade me that Dr. Brienza did not change his testimony during the hearing:

Q. Row 40 of schedule F of your rebuttal report, that last column, "Comparison with claims of the 392 Patent for Rideout." The tension rod means is the only element of claim 16 which you have identified the Rideout reference doesn't teach. Now, today, this morning, for the first time, you told me it also doesn't teach a hinge means between the supports; correct?

A. It doesn't describe a combination of a hinge means and a tension rod means. Here, here literally I'm saying it doesn't have a tension rod means. It does have a hinge. The hinge -- part of the understanding of the hinge is how it interacts with the tension rod means and how it's -- how they are synergistic, but I will agree

with you. In row 40, in the last column, I only identify the tension rod means as being missing.

Trial Transcript, Vol. 9, P. 1641, L. 2-16.

[369] Later, at page 1644, lines 22 to 28 this exchange takes place:

Q. Okay. That's what I am trying to identify. What are the essential elements of the hinge means of claims 16 and 18 that are not present in the hinge 23 of Rideout?

A. I think I said just a minute ago I will agree with you that that is a hinge means so we can get through this.

[370] Many, many more interchanges occurred; this part of the cross-examination essentially went around in circles.

[371] Near the end counsel took another turn at getting Dr. Brienza to agree that at trial he had changed his position from what he originally said in his reports:

Q. [. . .] So, first, you agree that the Rideout hinge 23 does exactly that?

A. That's what I don't agree with.

Q. It doesn't resist a pulling force?

A. That it doesn't structurally interconnect in the way that would be understood to the reader of the 392 Patent.

Trial Transcript, Vol. 9, P. 1652, L 28; P.1653 L 1-6.

[372] Shortly after that exchange, I concluded and said to counsel that it was time to move on as, after an hour of trying, he was not going to get Dr. Brienza to agree with him. At that point counsel continued with other questions about the Rideout and how it works but the hinge was

not revisited other than putting hypothetical propositions to Dr. Brienza based on the hinge in Rideout falling within his construction.

B. *Anticipation*

(1) The Law

[373] Section 28.2 of the *Patent Act* provides the statutory basis for attacking a patent based on an allegation of anticipation. The relevant parts of s.28.2 are:

<p>28.2 (1) The subject-matter defined by a claim in an application for a patent in Canada (the “pending application”) must not have been disclosed</p>	<p>28.2 (1) L’objet que définit la revendication d’une demande de brevet ne doit pas :</p>
<p>(a) more than one year before the filing date by the applicant, or by a person who obtained knowledge, directly or indirectly, from the applicant, in such a manner that the subject-matter became available to the public in Canada or elsewhere;</p>	<p>a) plus d’un an avant la date de dépôt de celle-ci, avoir fait, de la part du demandeur ou d’un tiers ayant obtenu de lui l’information à cet égard de façon directe ou autrement, l’objet d’une communication qui l’a rendu accessible au public au Canada ou ailleurs;</p>
<p>(b) before the claim date by a person not mentioned in paragraph (a) in such a manner that the subject-matter became available to the public in Canada or elsewhere;</p>	<p>b) avant la date de la revendication, avoir fait, de la part d’une autre personne, l’objet d’une communication qui l’a rendu accessible au public au Canada ou ailleurs;</p>

[374] Mr. Justice Binnie sets out, in *Free World Trust*, the test for anticipation at paragraph 26:

The test for anticipation is difficult to meet:

One must, in effect, be able to look at a prior, single publication and find in it all the information which, for practical purposes, is needed to produce the claimed invention without the exercise of

any inventive skill. The prior publication must contain so clear a direction that a skilled person reading and following it would in every case and without possibility of error be led to the claimed invention.

(*Beloit Canada Ltd v Valmet OY* (1986), 8 CPR (3d) 289 (FCA), per Hugessen JA, at p 297)

[375] The approach to determining whether an allegation of anticipation has been made requires two separate steps: disclosure and enablement: *Apotex Inc v Sanofi-Synthelabo Canada Inc*, 2008 SCC 61 at paras 24-26 [*Sanofi*].

[376] First, the prior patent must disclose subject matter which, if performed, would necessarily result in infringement of the patent at issue without any trial and error or experimentation by the POSITA who is simply to read the prior patent, trying to understand it: *Sanofi*, at para 25.

[377] Second, if the prior patent discloses the subject matter of the patent at issue, then it must be determined if the prior patent allows the POSITA to perform the invention of the patent at issue. At this stage, the POSITA may make trial and error experiments to get the invention to work: *Sanofi*, at paras 26 and 27.

[378] A non-exhaustive list of factors normally to be considered in determining whether enablement exists were set out at paragraphs 37 in *Sanofi*:

[37] Drawing from this jurisprudence, I am of the opinion that the following factors should normally be considered. The list is not exhaustive. The factors will apply in accordance with the evidence in each case.

1. Enablement is to be assessed having regard to the prior patent as a whole including the

specification and the claims. There is no reason to limit what the skilled person may consider in the prior patent in order to discover how to perform or make the invention of the subsequent patent. The entire prior patent constitutes prior art.

2. The skilled person may use his or her common general knowledge to supplement information contained in the prior patent. Common general knowledge means knowledge generally known by persons skilled in the relevant art at the relevant time.

3. The prior patent must provide enough information to allow the subsequently claimed invention to be performed without undue burden. When considering whether there is undue burden, the nature of the invention must be taken into account. For example, if the invention takes place in a field of technology in which trials and experiments are generally carried out, the threshold for undue burden will tend to be higher than in circumstances in which less effort is normal. If inventive steps are required, the prior art will not be considered as enabling. However, routine trials are acceptable and would not be considered undue burden. But experiments or trials and errors are not to be prolonged even in fields of technology in which trials and experiments are generally carried out. No time limits on exercises of energy can be laid down; however, prolonged or arduous trial and error would not be considered routine.

4. Obvious errors or omissions in the prior patent will not prevent enablement if reasonable skill and knowledge in the art could readily correct the error or find what was omitted.

(Beloit Canada Ltd. v. Valmet OY (1986), 8 C.P.R. (3d) 289 (F.C.A.), per Hugessen J.A., at p. 297)

(2) The 392 Patent was not anticipated

[379] Evolution alleges that the 392 Patent was anticipated by the Fernie patent. It argues that the Fernie patent would disclose the 392 Patent's invention to the skilled reader and that the skilled reader would be able to perform this invention from that reading.

[380] Evolution also alleges that Dr. Brienza admitted that all of the essential elements of Claims 16 and 18 are present in the Fernie patent. Human Care argues that this is an erroneous assertion and that Dr. Brienza was instead clear that the 392 Patent was not anticipated by the Fernie patent. I agree with Human Care, Dr. Brienza made no such admission.

[381] Human Care points out that the tension rod means of the 392 Patent is absent from the Fernie patent. Its equivalent in the Fernie patent, two swingable arms, incur no tensile loading and therefore are not a tension rod means within the meaning of Claims 16 and 18.

[382] I am satisfied that the Fernie patent does not anticipate the 392 Patent. The POSITA could not make the 392 Patent's invention from reading the Fernie patent without undue burden.

C. *Obviousness*

(1) The Law

[383] The *Patent Act* provides in s. 28.3 that an invention must not be obvious:

28.3 The subject-matter defined by a claim in an application for a patent in Canada must be subject-matter that would not have been

28.3 L'objet que définit la revendication d'une demande de brevet ne doit pas, à la date de la revendication, être évident pour une personne

obvious on the claim date to a person skilled in the art or science to which it pertains, having regard to	versée dans l'art ou la science dont relève l'objet, eu égard à toute communication :
(a) information disclosed more than one year before the filing date by the applicant, or by a person who obtained knowledge, directly or indirectly, from the applicant in such a manner that the information became available to the public in Canada or else-where; and	a) qui a été faite, plus d'un an avant la date de dépôt de la demande, par le demandeur ou un tiers ayant obtenu de lui l'information à cet égard de façon directe ou autrement, de manière telle qu'elle est devenue accessible au public au Canada ou ailleurs;
(b) information disclosed before the claim date by a person not mentioned in paragraph (a) in such a manner that the information became available to the public in Canada or elsewhere.	b) qui a été faite par toute autre personne avant la date de la revendication de manière telle qu'elle est devenue accessible au public au Canada ou ailleurs.

[384] In this case, obviousness is to be assessed as of the priority claim date of March 26, 2004.

[385] In considering obviousness, the CGK of the POSITA is limited to knowledge which is generally known by persons skilled in the relevant prior art at the relevant time: *Sanofi* at para 37(2).

[386] In *Janssen-Ortho Inc v Novopharm Ltd*, 2007 FCA 217 at para 25(3), the Federal Court of Appeal adopted the following description of CGK from the trial judgment of Mr Justice Hughes in the same case:

The common knowledge of the hypothetical person of ordinary skill in the art includes what the person may reasonably be expected to know and to be able to find out. The hypothetical

skilled person is assumed to be reasonably diligent in keeping up with advances in the field to which the patent relates (*Whirlpool* at paragraph 74). The presumed knowledge of the hypothetical skilled person undergoes continuous evolution and growth. Not all knowledge is found in print form. On the other hand, not all knowledge that has been written down becomes part of the knowledge that a person of ordinary skill in the art is expected to know or find.

[387] In this case, the POSITA's CGK includes the basic principles of design and construction of mobility aiding devices, including those which fold for storage, and a moderate knowledge and understanding design of load bearing structures.

[388] In *Dimplex North America Ltd v CFM Corporation*, 2006 FC 586, Mr. Justice Mosley set out the test from *Beloit Canada Ltd v Valmet Oy* (1986), 8 CPR(3d) 289, to the effect that the POSITA would have "no scintilla of inventiveness or imagination; a paragon of deduction and dexterity, wholly devoid of intuition." The test for obviousness being whether such a person would "in the light of the state of the art and of common general knowledge as at the claimed date of invention, have come directly and without difficulty to the solution taught by the patent."

[389] A further refinement of the test for obviousness was recognized by Madam Justice Snider in *Wenzel Downhole Tools Ltd v National-Oilwell Canada Ltd*, 2011 FC 1323 at paragraph 160:

[T]he test for obviousness requires that the prior art be something that would likely come to the attention of the person of ordinary skill in the art. It cannot be assumed that the unimaginative, non-inventive technician skilled in the art would consider art in other fields. There must be some reason, supported by evidence, which would justify a person skilled in the art – and not just experts prompted by counsel – to look beyond the field at issue.

[my emphasis]

[390] In *Frac Shack Inc v AFD Petroleum Ltd*, 2017 FC 104 [*Frac Shack*], Mr. Justice Manson recently outlined the four-part test as set out in *Sanofi*:

[204] Obviousness must be assessed on a claim-by-claim basis (*Zero Spill Systems (International) Inc v Heide*, 2015 FCA 115 at para 85). The four-part *Windsurfing-Pozzoli* test for obviousness was set down by the Supreme Court of Canada in *Apotex Inc v Sanofi-Synthelabo Canada Inc*, 2008 SCC 61 [*Sanofi*] at paragraph 67:

1. (a) Identify the notional person skilled in the art.

(b) Identify the relevant common general knowledge of that person.
2. Identify the inventive concept of the claim in question or if that cannot be readily done, construe it.
3. Identify what, if any, differences exist between the matter cited as forming part of the “state of the art” and the inventive concept of the claim or the claim as construed.
4. Viewed without any knowledge of the alleged invention as claimed, do those differences constitute items which would have been obvious to the person skilled in the art or do they require a degree of invention?

[205] Obviousness is a difficult test to meet, and where an expert is hired for the purpose of testifying a court must be wary of his or her hindsight bias (*Bridgeview Manufacturing Inc v 931409 Alberta Ltd (Central Alberta Hay Centre)*, 2010 FCA 188 at para 50 [*Bridgeview*]). It is not fair to a person claiming to have invented a combination invention to break it down into its constituent parts and find that, because the parts are well known, the combination is obvious (*Bridgeview*, above, at para 51). The question to be asked is would a POSITA, in the light of the state of the art and the common general knowledge, at the claimed date of the invention, have come directly and without difficulty to the invention in the patent (*Beloit Canada Ltd v Valmet Oy* (1986), 8 CPR (3d) 289 at 294).

[391] Mr. Justice Barnes has helpfully set out in *ABB Technology AG v Hyundai Heavy Industries Co, Ltd*, 2013 FC 947 the list of factors established by the Federal Court of Appeal in *Janssen-Ortho Inc v Novopharm Ltd*, 2007 FCA 217 (as outlined by Justice Snider in *Laboratoires Servier v Apotex Inc*, 2008 FC 825) that can be used as a framework for the factual inquiry and analysis to be undertaken in determining whether an invention was obvious:

Principal factors

1. The invention
2. The hypothetical skilled person referred to in the Beloit quotation
3. The body of knowledge of the person of ordinary skill in the art
4. The climate in the relevant field at the time the alleged invention was made
5. The motivation in existence at the time [of] the alleged invention to solve a recognized problem
6. The time and effort involved in the invention

Secondary factors

7. Commercial success
8. Meritorious awards

[392] The notional POSITA and the CGK of such a person have already been identified. I will turn therefore to determining the inventive concept of Claims 16 and 18 of the 392 Patent after which it will be compared to the cited prior art to determine what differences, if any exist, between the prior art and the inventive concept. The final step will be to consider the primary and secondary factors in order to determine whether the differences constitute items that would have been obvious to the POSITA.

(2) The Inventive Concept

[393] Dr. Brienza noted that all of the claims of the 392 Patent pertain to mobility aiding devices each with specific elements or components listed in the claim. He noted that the POSITA would have understood that the elements of each claim work together to provide a device with a solid seating platform made up of two pivotally connected sections, with structural reinforcements that fold up easily into a storage position.

[394] At paragraph 117 of his Responding Expert Report , Dr. Brienza stated:

In other words, it is my opinion that the skilled person would have understood the “inventive concept” of each claim to be a mobility aiding device compris[ed] of the particular elements of that claim where the elements work together to provide “a solid seating platform made up o[f] two pivotally connecting sections, with structural reinforcements,” and the device folds up “easily into a storage position.”

[395] Nothing is easier than to say, after the event, that the thing was obvious and involved no invention.

I confess that I view with suspicion arguments to the effect that a new combination, bringing with it new and important consequences in the shape of practical machines, is not an invention, because, when it has once been established, it is easy to show how it might be arrived at by starting from something known, and taking a series of apparently easy steps. This ex post facto analysis of invention is unfair to the inventors, and in my opinion it is not countenanced by English Patent Law.

The King v Uhlemann Optical Co (1949), 11 CPR 26 at 46 (Ex Ct)

(3) Essence of the Invention

[396] Evolution submits that Dr. Brienza's claim construction with respect to obviousness is faulty because he referred more than once to the "essence of the invention," which is said to be contrary to Canadian law as set out in *Free World Trust*.

[397] I do not agree that referring to "the essence of the invention," when it is considered in context, is contrary to Canadian law. The brief reference by Mr. Justice Binnie in *Free World Trust*, to the "essence or substance of the invention" at paragraph 39 was made as part of his determination that, when construing claims, the language of the claims is of primary importance and recourse cannot be made to "the essence of the invention".

[398] Mr. Justice Binnie was not banishing the words "essence of the invention" from the entirety of patent law. These words are still used to describe the inventive concept: *Eli Lilly Canada Inc v Apotex Inc*, 2015 FC 1016 at para 93; *Varco Canada Limited v Pason Systems Corp*, 2013 FC 750 at para 271 [*Varco*]. Mr. Justice Binnie was simply banishing the two-step process from claims construction.

[399] Having re-read the portions of the transcripts where Dr. Brienza referred to the "essence of the invention", it is apparent that he was not on those occasions construing the claims. I am satisfied that Dr. Brienza construed the claims purposively without resorting to the specification other than to verify his understanding of the claims. I note that he used the words "essence of the invention" and "inventive concept" interchangeably and only when he was explaining his

construction to counsel during cross-examination. He did not use the phrase in his written reports where he construed the claims.

[400] Viewed in context, Dr. Brienza's use of the phrase "essence of the invention" was not improper. It has no effect on the weight I attribute to his claims construction in respect of obviousness.

(4) The 392 Patent was not obvious

[401] Evolution alleges that Claims 16 and 18 are obvious given a portfolio of prior art, consisting primarily of the Fernie and Rideout patents.

[402] Mr. Schuch found that various aspects of the 392 Patent's invention would be obvious given the prior art, particularly when giving the claims the broad construction advocated for by Human Care. Human Care argues that Mr. Schuch did not correctly approach his obviousness analysis. Rather than engage in the four step approach from *Sanofi*, while trying to avoid the distortionary effects of hindsight, Mr. Schuch merely accumulated a portfolio of prior art with the benefit of hindsight in an effort to invalidate the 392 Patent.

[403] I agree with Human Care, Mr. Schuch erred in his approach to the obviousness analysis. Prior art is only relevant to obviousness insofar as it establishes the "state of the art", as known by the POSITA at the relevant date. Moreover, as Mr. Justice Rothstein stated at paragraph 52 of *Sanofi*, obviousness is a difficult test to satisfy, and I am not convinced that Mr. Schuch's evidence has done so.

[404] The evidence from Mr. Pita was that Evolution had attempted, on and off, from 2001 or 2002 until late 2006 or early 2007 to develop a centre folding walker without success. Initial designs were found to be too heavy and too expensive to manufacture. The early attempts failed and there was no real motivation at that time to continue as there were no centre-folding products on the market.

[405] When the Nexus came to market attempts were resumed by Evolution in or about late 2006 or early 2007 at which time Evolution spent a year in design. During that period they did a patent search to see what else was on the market. Time, money and effort was expended by Evolution on two different occasions years apart looking for a way to build an affordable centre-folding rollator. That evidence also supports a finding of non-obviousness: *Sanofi* at para 71.

(a) *Commercial Success*

[406] Both parties also engaged with the commercial success of the 392 Patent, a secondary factor in considering obviousness.

[407] Evolution emphasises the secondary nature of this factor and argues that, in any event, the 392 Patent has not enjoyed significant commercial success, in part because it has not resulted in significant sales in the United States of America.

[408] Human Care notes that, despite being a secondary factor, the Federal Court of Appeal has held commercial success to be an important factor in the obviousness analysis, overturning the trial decision in *Beloit* because of the trial judge's failure to consider it. Human Care argues that

its Nexus product, the commercial embodiment of the 392 Patent as found by Dr. Brienza, has enjoyed considerable commercial success in Canada-greater than its previous products.

[409] Commercial success does not need to be worldwide to be relevant. At trial evidence was led that the market in the United States is quite different than in Canada, including the pricing. Additionally, Human Care argues that Evolution would not be marketing its own centre-folding, solid seat rollators if the 392 Patent was not commercially successfully.

[410] Each of these factors individually suggest that, had the 392 Patent been obvious, Evolution would have been both properly motivated and informed to create the device itself.

D. *Overbreadth*

(1) The Law

[411] The relevant date for determining overbreadth is the date of publication which is September 25, 2005 – the same date as the date for construing the claims.

[412] The content required in an application for a patent is set out at s. 27 of the *Patent Act*.

Subsections 27(3) and (4) stipulate as follows:

Specification	Mémoire descriptif
(3) The specification of an invention must	(3) Le mémoire descriptif doit :
(a) correctly and fully describe the invention and its operation or use as contemplated by the inventor;	a) décrire d'une façon exacte et complète l'invention et son application ou exploitation, telles que les a conçues son inventeur;

- | | |
|--|--|
| <p>(b) set out clearly the various steps in a process, or the method of constructing, making, compounding or using a machine, manufacture or composition of matter, in such full, clear, concise and exact terms as to enable any person skilled in the art or science to which it pertains, or with which it is most closely connected, to make, construct, compound or use it;</p> | <p>b) exposer clairement les diverses phases d'un procédé, ou le mode de construction, de confection, de composition ou d'utilisation d'une machine, d'un objet manufacturé ou d'un composé de matières, dans des termes complets, clairs, concis et exacts qui permettent à toute personne versée dans l'art ou la science dont relève l'invention, ou dans l'art ou la science qui s'en rapproche le plus, de confectionner, construire, composer ou utiliser l'invention;</p> |
| <p>(c) in the case of a machine, explain the principle of the machine and the best mode in which the inventor has contemplated the application of that principle; and</p> | <p>c) s'il s'agit d'une machine, en expliquer clairement le principe et la meilleure manière dont son inventeur en a conçu l'application;</p> |
| <p>(d) in the case of a process, explain the necessary sequence, if any, of the various steps, so as to distinguish the invention from other inventions.</p> | <p>d) s'il s'agit d'un procédé, expliquer la suite nécessaire, le cas échéant, des diverses phases du procédé, de façon à distinguer l'invention en cause d'autres inventions.</p> |

Claims

(4) The specification must end with a claim or claims defining distinctly and in explicit terms the subject-matter of the invention for which an exclusive privilege or property is claimed.

Revendications

(4) Le mémoire descriptif se termine par une ou plusieurs revendications définissant distinctement et en des termes explicites l'objet de l'invention dont le demandeur revendique la propriété ou le privilège exclusif.

[413] Rule 84 of the *Patent Rules*, SOR/96-423 imposes further requirements on the clarity and scope of the claims. It states as follows:

84 The claims shall be clear and concise and shall be fully supported by the description independently of any document referred to in the description.

84 Les revendications sont claires et concises et se fondent entièrement sur la description, indépendamment des documents mentionnés dans celle-ci.

[414] The question to be determined when dealing with an argument that a claim is overbroad is whether the claim at issue exceeds the scope of the disclosure on which the claim is based:

Abbott Laboratories v Canada (Minister of Health), 2004 FC 1349.

[415] The Joint Statement of Issues submitted by the parties includes the following questions addressing Overbreadth:

Was the subject-matter of claims 1 to 18 of the 392 Patent broader than the invention made or described in the 392 Patent specification.

In Particular:

(a) Does the element “an extended position in which said tension rod structurally interconnects said first and second supports, when the device is in the use position” encompass anything other than a proximate or local structural connection bridging the first and second supports to achieve the structural interconnection? If so, are the claims invalid for exceeding the invention actually made or described in the 392 Patent specification?

(b) Does the “handle” element in claims 6-8, 11, 12, 13 and/or 18 encompass any mechanism that achieves the desired result of pivoting said tension rod means into the release position or pivoting said first and second supports into the storage position by any means other than those described and illustrated in the patent specification and drawings? Namely by:

(i) being a handle attached directly to the tension rod and pulling it upward when the handle is pulled upward; or

(ii) passing through the first and second supports rather than through the seat?

If so, are claims 6-8, 11, 12, 13 and/or 18 invalid for exceeding the invention actually made or described in the 392 Patent specification?

[416] Valid claims must not be broader than either (1) the new and useful invention as invented by the inventor; or (2) the invention as described in the patent (*Pfizer*, above, at para 116).

Therefore, the Court must ask whether the claims read fairly on what has been disclosed and illustrated in the specification and drawing (*Pharmascience Inc v Pfizer Canada Inc*, 2011 FCA 102 at paras 40 to 41): *Frac Shack* at paragraph 203.

(2) The Arguments of the Parties

[417] The primary dispute between the parties is that Human Care says the allegation of overbreadth is based on the 392 Patent specifying just one embodiment. Evolution, who supports that argument, says that anything else is therefore not specified and the claims are broader than the invention. I have previously found the argument that the claims should be confined to the preferred embodiment to be without merit.

[418] Human Care also objects to the inclusion of extrinsic evidence speaking to the inventors' state of mind. It asserts that covetous claiming or overbreadth is a form of claims' construction and extrinsic evidence is not permitted. I agree. Mr. Justice Barnes stated in *Bayer Healthcare AG v Sandoz Canada Incorporated*, 2007 FC 1068 at paragraph 8 aff'd 2008 FCA 309 that

“[w]hether a patent claim is covetous is a matter of construction and, therefore, it could be found to be so without resorting to any extrinsic evidence.”

[419] While the inventors’ state of mind is not admissible Evolution was not precluded from presenting expert evidence to assist the Court in arriving at a conclusion that the claims as construed are overly broad. I have not been so persuaded. I have agreed with the construction of claims put forward by Dr. Brienza for the reasons already given.

[420] I have construed the “Tension Rod Means”, “structurally interconnect”, the Handle, “extending through”, the cross braces “extending between” as including either direct and indirect connections or limitations that prevent them from being overly broad. The POSITA with the relevant CGK would understand the patent as a whole, including the entirety of the specification, to disclose the claims as I have construed them. Additionally, the claims as construed do not disclose anything broader than what the inventors actually invented.

E. *Mere Aggregation*

(1) The Law

[421] Apart from anticipation and obviousness, the combination of known elements comprising an invention must lead to a unitary result. If the invention leads to a succession of results, then the invention is a mere aggregation of known elements and therefore is not patentable: *The King v American Optical Co*, [1950] Ex CR 334 at 22.

[422] However, the majority of modern inventions are novel combinations of known elements and are nonetheless the proper subject matter of patents: *International Pediatric Products Ltd v Lambert* (1966), 50 CPR 265 at para 4. Consequently, the courts do not often find patents to be invalid for being mere aggregations.

(2) The 392 Patent is not a mere aggregation

[423] Evolution argues that each of Claims 1 to 18 of the 392 Patent are invalid as being mere aggregations that fail to yield a unitary result. Mr. Schuch found in his report that each individual element of the invention works in the way that the POSITA would expect it to. Mr. Schuch only identified two potential unitary results, the prevention of pinching and the strengthening of weight bearing capacity. Mr. Schuch's analysis is based on his narrow claims construction where each individual element was considered using the definitions provide by Mr. Schuch and without considering the context in which the claims are found in the 392 Patent.

[424] Evolution also alleges that these are not proper unitary results because Claims 16–18 can be so broadly construed as to vitiate these unitary results.

[425] Human Care argues that a broader approach should be taken regarding the unitary result of the 392 Patent. Dr. Brienza's report determines the unitary result, in light of the patent as a whole, to be a mobility aiding device with a solid seating platform that avoids the shortcomings of other such devices in the prior art.

[426] I agree with Human Care, the 392 Patent is not a mere aggregation. The evidence shows the result achieved through the combination of elements was inventive and successful. Simply because the individual elements of the invention function in the manner they normally do, it does not mean that the 392 Patent is a mere aggregation. The ingenious combination of elements in the 392 Patent was neither taught nor anticipated in the prior art.

X. **Remedies**

[427] The parties presented a list of issues to the Court in the event that the 392 Patent was found to be valid and infringed. Accordingly, I will follow the list provided and supplement it as may be required in light of matters that arose during the trial.

A. *Damages – Reasonable Remedy*

[428] The parties have agreed in the ASF that:

Between July 2008 to the present, Evolution has offered for sale, sold, imported into Canada, and exported from Canada, Xpresso rollators which includes Xpresso, Xpresso Lite, Xpresso Zero, Xpresso Tacoma and all sizes and variations thereof. Between July 2008 to the present, Evolution has assembled in Canada Xpresso Zero rollators.

From July 2008 to the present, Evolution has offered for sale, sold, imported into Canada, exported from Canada, and assembled in Canada Xpresso Parts & Accessories.

[429] The parties have also agreed that, should the 392 Patent be found to be valid and infringed by Evolution, a proper measure of damages under ss. 55(2) of the *Patent Act* is a reasonable royalty for Evolution's use of Human Care's patented technology from the launch of the Xpresso in July 2008 until the 392 Patent was issued on November 30, 2010. They also agree

that the most appropriate manner in which to quantify a reasonable royalty is to look at the actual royalty rates paid in respect of the Nexus rollators from 2006 to 2011.

[430] For the purposes of this proceeding, prior to July 1, 2010, the royalty rate per Nexus rollator unit was [REDACTED] and that from July 1, 2010, the royalty rate per Nexus rollator unit was [REDACTED].

[431] It is agreed by the parties that the total reasonable royalty calculation for the period from July 1, 2008 to November 30, 2010 is \$241,022.

[432] The parties have not resiled from that agreement. There is nothing to discuss.

[433] Human Care is entitled to the amount of \$241,022 as a reasonable royalty for the period July 1, 2008 to November 30, 2010.

B. *Is Human Care Entitled to Evolution's Profits in Respect of Its Xpresso Products?*

[434] In its Statement of Claim, Human Care elected the right to either damages suffered or an accounting of Evolution's profits (as it may elect) after full discovery as to each. In July 2016, after completing discovery and before delivering Ms. Rogers' report, Human Care notified Evolution that it was electing an accounting of profits.

[435] In its Statement of Defence, Evolution had simply denied that Human Care is entitled to any remedy or relief as claimed. Evolution led no evidence at trial to support the bald assertion

that if it was found to have infringed the 392 Patent, then Human Care is not entitled to an accounting of profits. Neither did it raise any argument to this effect.

[436] An accounting of profits is an equitable remedy. Whether or not it is an appropriate remedy varies according to the circumstances of the case and the discretion of the Court.

Relevant factors to consider in determining whether an accounting for profits is appropriate include whether the patentee delayed in commencing an action, whether the infringer knowingly infringed and whether the patentee practiced the invention of the patent in Canada: *Frac Shack*, at paras 282-283. There was no delay by Human Care in commencing this action, which began in 2012, and it has put in practice the invention described in the 392 Patent.

[437] Evolution in its submissions did not dispute that Human Care is entitled to an accounting of profits. As will be seen, Evolution does dispute the way the accounting of profits should be calculated.

[438] An accounting of Evolution's profits is the appropriate remedy in this case.

C. *Agreed Upon Facts Relevant to an Accounting of Profits*

[439] Evolution sales of its Xpresso rollators from December 1, 2010 to June 30, 2016 were

■■■■ units:

Period	Units Sold
December 1, 2010 - June 30, 2011	■■■■
July 1, 2011 - June 30, 2012	■■■■

July 1, 2012 – June 30, 2013	██████████
July 1, 2013 – June 30, 2014	██████████
July 1, 2014 - June 30, 2015	██████████
July 1, 2015 - June 30, 2016	██████████
TOTAL	██████████

[440] The total sales revenue during that time from the Xpresso rollators and the Xpresso Parts & Accessories, as defined by the parties in their ASF and together referred to as the “Xpresso Products,” was ██████████.

[441] Evolution's total Freight Cost for Xpresso Products from December 1, 2010 to June 30, 2016 was ██████████.

D. *General Legal Principles of an Accounting of Profits*

[442] An accounting of profits has been considered as “a deterrence tool and a mechanism for restorative justice in the commercial world”: *Varco*, at para 398. Given the discretionary character of an accounting of profits, the Federal Court of Appeal has stated that “absent proof of a bar to equitable relief, a claimant can expect to be granted the remedy it seeks in accordance with the principles governing its availability”: *Apotex Inc v Bristol-Myers Squibb Co*, 2003 FCA 263 at para 14.

[443] In its written submissions, Evolution set out legal principles for an accounting of profits including the following passages, all from *Dow Chemical Company v Nova Chemicals Corporation*, 2017 FC 350 [*Dow*] citing various other judgments:

a plaintiff is entitled only to that portion of the infringer's profit that is causally attributable to the invention: para 108;

the remedy of an accounting of profits is restitutionary in nature, not punitive; it is the wrong-doer who is being restored, through a disgorgement of profits, to the position that he would have been in had he not done the illegal act: para 109;

[a] comparison is to be made between the defendant's profit attributable to the invention and his profit had he used the best non-infringing option: at para 164;

[t]he "best non-infringing option" has generally been interpreted to mean a "true substitute" or "real alternative": para 164; [and]

at bottom is the need to ensure that a patentee only receives that portion of the infringer's profit that is causally attributable to the invention: para 164.

E. *Evolution's Differential Profits Approach*

[444] Evolution instructed Mr. Gain to provide an expert opinion as to "the differential profits earned by Evolution as a result of its alleged infringement" of the 392 Patent from December 1, 2010 to June 30, 2016 relating to the manufacture, offering for sale, sale and export of Evolution's line of Xpresso rollators in Canada.

[445] In his closing submissions, counsel for Evolution provided what appears to be the reason for those instructions:

[w]hat we are asserting is that we would have made the sales that we actually made. These are real sales to real customers of products that are unrelated to the Xpresso walker. That's the but-for world we are working with.

Trial Transcript, Vol. 12, P. 2080, L. 21-27.

[446] Mr. Gain's explanation of his approach and underlying assumptions is:

I have assumed that all purchasers of Xpresso walkers made their purchases based on the fact that those walkers were centre-collapsing. I assume that but for the alleged infringement, Evolution would not have been able to replace any of the sales of allegedly infringing walkers with alternative, non-infringing walkers.

Gain Expert Report, at para 84.

[447] When Mr. Gain performed his calculation he arrived at an amount of either [REDACTED] or [REDACTED] as Evolution's "differential profits." He also calculated profits not from the non-sales of the Xpresso rollator but rather by applying the differential profit approach on a company-wide basis. In doing so, he reasoned that:

- a significant majority of Evolution's sales during the time period in question were Xpresso rollators;
- without sales of the Xpresso rollators, Evolution would have significantly reduced the scale of its operations and be a much smaller company;
- the difference between the actual profits earned by Evolution from selling the Xpresso rollators and the profits that would have been earned without any Xpresso rollator sales is categorized as the "but for" world (a world in which all Xpresso rollator sales were lost);
- without the Xpresso rollators, Evolution would have sold only non-Xpresso rollators earning the industry average net profit margin of [REDACTED]; and
- alternatively, Evolution would have operated on a breakeven basis or have ceased operating altogether.

[448] I do not accept that the approach taken by Mr. Gain properly calculates the accounting of profits. Even under a differential profits approach, Mr. Gain does not properly calculate the amount owing because when there is no non-infringing alternative, there is no revenue to subtract.

F. *Analysis of Evolution's Differential Profits Approach*

[449] Evolution urges the court to find that the portion of its profits causally attributable to the infringing sales of Xpresso rollators is to be determined by taking Evolution's total profits and subtracting the profits that it would have earned if no infringing products had been sold. The argument is that:

. . . the non-infringing option is not replacing sales with a non-infringing alternative. The non-infringing option in this case is simply a loss of all the Xpresso walker sales.

Trial Transcript Vol. 12, P. 2079, L. 17 – 20.

[450] The logic behind Evolution's submission is what it calls a "very nuanced" point: there is a difference between a "non-infringing option" as mentioned in *Schmeiser*, referred to in *Dow* at paragraph 164 and a "non-infringing alternative" in the sense of a "true substitute" or "real alternative" as referred to in *Apotex Inc v Merck & Co, Inc*, 2015 FCA 171.

[451] Evolution acknowledges that "at bottom is the need to ensure that the patentee only receives that the portion of the infringer's profit that is causally attributable to the invention." Evolution then says the question with which the experts are meant to assist the court when applying the differential profits approach is "[w]hat position would the defendant have been in had he not done the illegal act?"

[452] The problem with the argument by Evolution is that the factual matrix in the present case is far different from that which faced Mr. Schmeiser, the outcome of which turned on there being no causal connection between the profits he made from selling Roundup Ready Canola and that

which he could have made selling canola that had not been treated with Roundup: *Schmeiser* at paras 104-105.

[453] Evolution, however, repeatedly admitted that there was no real non-infringing alternative in this case. For example, counsel for Evolution stated the following:

In this case there is no non-infringing alternative. The non-infringing world means not a single Xpresso walker was sold.

Trial Transcript, Vol. 12, P. 2077, L 8 – 10.

[454] Moreover, Evolution would have only been able to sell its pre-existing non-infringing products, no Xpresso sales would have occurred. On that basis the scenarios calculated by Mr. Gain run from a net profit margin of [REDACTED], being the industry average, to a breakeven rate or ceasing to operate the business altogether.

[455] It seems to me that the inevitable conclusion from each of those scenarios is that the profits Evolution earned were causally connected to the Xpresso infringing sales. If the Xpresso rollators had not been sold, then the company may have gone out of business. Therefore, I find that Evolution did not have a non-infringing alternative available to it during the infringement period.

[456] In any event, as set out in the following section, I prefer to adopt the interpretation of the calculation of an accounting of profits that has traditionally been followed, as in *Frac Shack* and *Varco*.

G. *The Appropriate Accounting Method to Determining Evolution's Profits*

[457] To determine the method for an accounting of profit by Evolution, this Court in *Varco* (at paragraph 417) has provided a six-part framework to quantify such profits:

1. Causal connection: there must be a causal connection between the profits made and the infringement.
2. Gross profits from infringement: based on calculating the gross revenues from infringement and deducting the incremental costs of earning that revenue.
3. Non-infringing option: whether such an option exists.
4. Disgorgement: absent a non-infringing option, the gross profits are paid to the patentee.
5. Gross profits from non-infringement: only relevant if there is a non-infringing option.
6. Disgorgement (net): only relevant where there is a difference between the gross profits of infringement and the gross profits of non-infringement.

[458] Step 1 requires a causal connection between the profits made by the infringer and the infringement. Neither party vigorously argued this point. Causation is not an issue. The Xpresso infringes the 392 Patent, so all profits realized from its sales of the Xpresso rollators after the 392 Patent was issued are causally connected to its infringement.

[459] Steps 3 to 6 all involve consideration in one form or another of a non-infringing option. Evolution has admitted there is no non-infringing option available to it.

[460] When there is not a non-infringing option, step 4 triggers step two. The consequence flowing from the lack of a non-infringing alternative is that “the infringer must turn over all

profits made from the infringing act, less legitimate expenses incurred”: *Frac Shack* at para 291; *Apotex Inc v Lundbeck A/S*, 2013 FC 192 at paras 282-283.

[461] In other words, when there is no non-infringing alternative, the differential profit approach and the actual profit approach are the same: there is no alternative and therefore no profits to deduct under step 6. The calculation of gross profits is simplified to taking the gross profits from the infringement then subtracting the gross profits from non-infringement, which are zero.

H. *What Costs, if any, are Deductible from Evolution’s Xpresso Revenues, and in What Proportion?*

[462] Where there is no non-infringing alternative, the infringer must turn over all profits made from the infringing act, less legitimate expenses incurred: *Apotex Inc v Lundbeck A/S*, 2013 FC 192 at paras 282-283 cited at para 292 of *Frac Shack*.

[463] Evolution has the onus to prove the costs to be deducted: *Dow*, at para 131.

[464] In *Rivett*, Mr. Justice Zinn at paragraph 67 summarized how a court is to approach the deductions in an accounting of profits analysis:

[67] . . . I accept and endorse the view expressed by Justice Reed in *Diversified Products Corp. v. Tye-Sil Corp.* (1990), 32 C.P.R. (3d) 385 (F.C.T.D.) [at page 390], that any doubt in determining the costs is to be resolved in favour of the plaintiffs:

In establishing an infringer’s profits, the plaintiff is required to prove only the defendant’s sales; the burden then shifts to the defendant to prove the elements of cost to be deducted from the sales in arriving at profit. Any doubts as to the computation

of costs or profits is to be resolved in favour of the plaintiff. At the same time, this does not mean that the infringer must prove expenses such as overhead and their relationship to the infringing product in minute detail. But the defendant bears the burden of explaining, at least in general terms, how claimed overhead costs actually contributed to the production of the infringing product.

However, I am also guided by the fact that the remedy the plaintiffs seek is essentially an equitable remedy and equity must be done to both parties. The Federal Court of Appeal in *Schmeiser* noted at paragraph 85 that if the application of accounting principles in a mechanical fashion results in a quantum that not does reflect the economic profit from the infringement, it is open to a trial judge to adjust the quantum, provided it is done on a “principled basis.”

[465] In *Teledyne Industries Inc v Lido Industrial Products Ltd*, 68 CPR (2d) 204, [1982] FCJ No 1024 [*Teledyne*], Mr. Justice Addy on page 213 provided the following guidance on deductible expenses:

To summarize: the infringer is entitled to deduct only those expenses, both variable and fixed, which actually contributed to the sums received and for which he is liable to account. It follows that no part or proportion of any expenditure which would have been incurred had the infringing operation not taken place, is to be considered as deductible.

[466] In summary, whether expenses are deductible is determined by (i) the particular circumstances of each case and (ii) the evidence proffered by the defendant of how the impugned expenditure related to the infringing product.

(1) Deductible Expenses Claimed by Evolution

(a) *Sales and Administrative Costs – EVO-56*

[467] Human Care objected at trial to a document produced by Evolution which was referred to as EVO-56. The document is said to be a reformatted version of information from Evolution's accounting system [Simply Accounting] that was prepared for the purpose of litigation.

[468] Evolution maintained that EVO-56 was a business record. It was produced at trial relying on s. 30 of the *Canada Evidence Act*, RSC 1985, c C-5.

[469] EVO-56 purports to provide details of the Sales and Administrative costs incurred for various categories of expenses such as advertising, administrative costs relating to the sale of the Xpresso and the monthly cost of goods sold for all Evolution Products sold.

[470] Human Care objected that it was not a business record and could not be produced as such as it did not fall under the exception to the hearsay rule for business records.

[471] I have no hesitation in finding that EVO-56 is not a reliable document. There was evidence from Mr. Pita that Evolution does not generate financial reports in the usual course of business. Mr. Stephen Liu, ostensibly in charge of the financial oversight, did not check or review the source documents when preparing disclosure in this matter; he took instructions from his father Mr. Julian Liu who was not called a trial to testify. Most importantly, Mr. Gain qualified his expert report as follows at paragraph 49:

49. My scope of review has been limited. I have not been provided with all of the information required to complete my review. In particular, the following information would have been of assistance:

- a) Annual financial statements for Evolution for the fiscal years ended 2001 to 2016;
- b) Annual financial statements for HCC/Dana Douglas for the fiscal years ended 2004 2008;
- c) General ledger details for the “accounting and legal”, “advertising”, “consultant fees” and “wages-direct” line items on Evolution’s SG&A summaries (EVO-56).

[472] The information in EVO-56 does not meet the test for the business records exemption and cannot be admitted.

(b) *Accounting and Legal Fees*

[473] Mr. Gain deducted Evolution’s accounting and legal fees from the actual profit. Human Care asserts that this line item “increased substantially” over the period from 2010 in which it was [REDACTED] to 2016 where the amount was [REDACTED].

[474] On cross-examination Mr. Gain conceded that expenses concerning accounting and legal fees had to be “normalized.” Human Care also argues that Evolution’s increase in litigation is likely related to its litigations that are unrelated to this dispute as suggested by Mr. Pita. Therefore, according to Human Care, Evolution’s accounting and legal fees “should be capped as they stood in 2010.”

[475] Evolution does not take an express position on its accounting and legal fees, in particular the increase that occurred.

[476] This Court has been generally hesitant to accept deductions for legal fees. For instance, in *Teledyne*, Mr. Justice Addy at paragraphs 214-216 did not allow the defendant to deduct legal expenses because it was concluded that such an approach would allow the infringing party to retain part of its unjust enrichment.

[477] Considering the case law and Evolution's failure to provide persuasive evidence accounting for the increase in its legal and account fees, I will allow the amount of [REDACTED] as a deduction. That is the amount that Evolution spent prior to the litigation in this and a parallel dispute.

(c) *Consulting Fees*

[478] Evolution seeks to deduct consulting fees of [REDACTED] for the fiscal years 2013 and 2014. Evolution claims that the increases in the consulting fee results from commissions for designs prior to opening research and design departments.

[479] For the time period July 1, 2012 to June 30, 2013 Evolution's Consultant Fees jumped from [REDACTED].14 the previous year to [REDACTED] and then to [REDACTED] the following year. It may well be a coincidence that it was during that time that this litigation began. As Evolution could not produce to Mr. Gain any documentation to support the consulting expenses, they cannot be allowed as Evolution has not met its evidentiary burden to support these deductions.

Mr. Gain testified that he accepted them because he didn't see anything untoward suggesting the payments had been made for any other purpose.

[480] I am prepared to allow Evolution consultant fees of [REDACTED] which is the average annual consultant fee for the three years July 1: 2009 to June 30, 2010, July 1, 2011 to June 30, 2012 and July 1, 2014 to June 30, 2015.

(d) *Other Discretionary Deductions Claimed*

[481] Evolution claimed other deductions—which Human Care contested—including wage increases, office expenses in Vancouver, and travel expenditures.

[482] Similar to the deductions analyzed above, these deductions also suffer from a lack of objective evidence on the basis of which this Court could assess whether they are appropriate expenditures that are deductible in an accounting of profits analysis. Consequently, rather than complete the same exercise, which is essentially a raw guess, I am satisfied that the process Ms. Rogers applied in scenario 4(a), given her expertise, is a reasonable recognition of the expenses which Evolution failed to prove.

I. *Conclusions on Accounting of Profits*

[483] Given that Evolution is permitted to make some discretionary deductions but have not provided fulsome evidence on their expenditures I accept Ms. Rogers' "rough justice" approach in her scenario 4(a). Therefore, I order Evolution to pay Human Care a total of \$12,156,745.

J. *Is Human Care Entitled to a Permanent Injunction?*

[484] Human Care is seeking a permanent injunction pursuant to ss. 57(1)(a) of the *Patent Act*. Evolution did not take an express position on this relief in its written or oral submissions.

[485] I am mindful of Madam Justice Gauthier's guidance at paragraph 240 in *Valence Technology, Inc v Phostech Lithium Inc*, 2011 FC 174 where she stated that "[t]he Court should refuse to grant a permanent injunction where there is a finding of infringement, only in very rare circumstances." Moreover, the case law is clear that a permanent injunction is usually granted to a successful plaintiff where the patent has been found to be valid and infringed: *Janssen-Ortho Inc v Novopharm Limited*, 2006 FC 1234 at para 133.

[486] Based on the case law and Evolution's silence on this point, I am satisfied that Human Care is entitled to a permanent injunction with respect to the manufacture, the use, the exportation, the distribution, the offer for sale and sale of the Xpresso.

K. *Should Profits-on-Profits be granted*

[487] Profits-on-profits is an equitable remedy. While Human Care sought this relief, it did not provide thorough submissions on why profits-on-profits is merited in this case. Accordingly, I am not satisfied it would be appropriate to award this relief

XI. **Costs**

[488] Rule 400(1) of the *Rules* accords this Court the "full discretionary power over the amount and allocation of costs." The Federal Court of Appeal has described this as the "first principle in

the adjudication of costs”: *Consorzio del prosciutto di Parma v Maple Leaf Meats Inc*, 2002 FCA 417 at para 9.

[489] In light of the infringement, the Plaintiff is entitled to its costs.

[490] During the hearing, both parties suggested that they may be able to agree on costs. I encourage them to do so.

[491] In the event that the parties cannot agree on the amount costs, the parties are referred to an Assessment Officer, in accordance with the established jurisprudence of this Court: *Eli Lilly Canada Inc v Apotex Inc*, 2015 FC 1165 at para 24.

XII. **Pre- and Post-Judgment Interest**

[492] Human Care is entitled to pre-judgment and post-judgment interest in the usual course.

JUDGMENT IN T-1556-12

THIS COURT’S JUDGMENT is that:

[1] The Plaintiff is entitled to:

- (a) a declaration that the 392 Patent and each of its claims are valid;
- (b) a declaration that the Defendant infringed Claims 16 and 18 of the 392 Patent;
- (c) an order for reasonable compensation in the amount of \$241,022;
- (d) an order for an accounting and disgorgement of profits currently set at \$12,156,745;
- (e) a permanent injunction restraining Evolution and its respective directors, officers, servants, agents, employees and all those acting by, through or with the direction and control of Evolution, from infringing the 392 Patent;
- (f) an order directing the delivery up to the Plaintiff or the destruction upon oath of all infringing products in the possession, custody or control of the Defendant;
- (g) pre and post judgment interest to be calculated; and
- (h) costs of the proceedings follow the event and the parties are to advise the Court on a jointly agreed amount within 14 days pursuant to Column IV of the Court’s Tariff B; if parties cannot agree on a costs disposition, they are referred to an Assessment Officer.

“E. Susan Elliott”

Judge

FEDERAL COURT
SOLICITORS OF RECORD

DOCKET: T-1556-12

STYLE OF CAUSE: HUMAN CARE CANADA INC. v EVOLUTION TECHNOLOGIES INC.

PLACE OF HEARING: TORONTO, ONTARIO

DATE OF HEARING: SEPTEMBER 5, 6, 7, 8, 11, 12, 13, 14, 15, 18, 19, 25, 2017

PUBLIC JUDGMENT AND REASONS: ELLIOTT J.

DATED: DECEMBER 21, 2018

APPEARANCES:

Kristin Wall
Amy Grenon
Chelsea Nimmo

FOR THE PLAINTIFF

Kenneth D. Hanna
Matthew R. Norwood
Christopher C. Langan

FOR THE DEFENDANT

SOLICITORS OF RECORD:

Norton Rose Fulbright LLP
Barristers and Solicitors
Toronto, Ontario

FOR THE PLAINTIFF

Ridout & Maybee LLP
Barristers and Solicitors
Toronto, Ontario

FOR THE DEFENDANT